

**CS Series**  
**SYNTHESIZER**  
**Service Guide**

**YAMAHA**

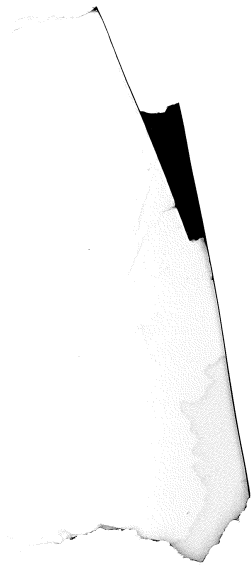

---

# CONTENTS

---

<b>Introduction</b> .....	1
<b>Function of Panel Lever</b> .....	2
(I) Panel 1 .....	2
(II) Panel 2 .....	5
(III) Panel 3 .....	6
(IV) Rear Panel .....	7
(V) Others .....	7
<b>CS-50 Circuit Board Contents</b> .....	8
<b>Basic Block Diagram of CS</b> .....	9
<b>Keyboard</b> .....	10
<b>Key Data Producing (Encoding) Circuit</b> .....	11
Key Data Producing Circuit .....	11
PIN Terminal Description of LSI (YM26600) .....	12
Reference .....	13
Timing Clock ( $\phi$ , $\overline{SC}$ , $\overline{SC8}$ ) .....	13
Data Processing Based on Time-sharing .....	13
Control of Produced Notes .....	13
Operational Principle of KEY Data Producing Circuit .....	13
KEY Coder .....	14
Output Timing Chart for KEY Coder .....	16
KEY Assigner .....	16
<b>KEY Voltage Detecting Circuit</b> .....	20
Basic Construction of KEY Voltage Detecting Circuit .....	20
PIN Terminal Description of LSI (YM26700) .....	20
Timing Clock ( $\phi$ , $\overline{SC}$ , $\overline{SC8}$ ) .....	21
Operational Principle I of KEY Voltage Detecting Circuit .....	22
D-A Converter .....	23
Operational Principle II of KEY Voltage Detecting Circuit .....	24
Portamento Operation .....	24
Operational Principle III of KEY Voltage Detecting Circuit .....	25
<b>Voltage-Controlled Oscillator</b> .....	27
Basic Construction of Sound Source Circuit .....	27
PIN Terminal Description of VCOIII (IG00153) .....	27
Operational Principle of VCO III (IG00153) .....	28
Outline of VCO III Circuit Operation .....	29
Transposition Circuit .....	30
Wave Shaper Converter Circuit (WSC) .....	31
Noise Source Circuit .....	32

---

---

<b>Voltage Controlled Filter</b> .....	33
Basic Construction of Voltage Controlled Filter .....	33
Operational Principle of LSI (IG00156) .....	33
Outline of VCF Circuit Operation .....	34
<b>Voltage Controlled Amplifier Circuit</b> .....	39
Basic Construction of VCA Circuit .....	39
Operational Principle of LSI (IG00151) .....	40
Outline of VCA Circuit Operation .....	40
<b>Envelope Generator</b> .....	42
Basic Construction of Envelope Generator .....	42
Operational Principle of LSI (IG00159) .....	43
Outline of VCA-EG Operation .....	44
Outline of VCF-EG Operation .....	45
<b>Expression Circuit</b> .....	46
<b>Output Amplifier and Headphone Amplifier</b> .....	48
<b>Modulator Circuit</b> .....	49
1. PWM Oscillator Circuit .....	49
2. Ring Modulator .....	50
3. Sub-oscillator and Touch Response .....	54
<b>Control Voltage Mixing Circuit</b> .....	59
1. VCO Vibrato Control Voltage Mixing Circuit .....	59
2. VCF Cut-OFF Frequency ( $f_c$ ) Control Voltage Mixing Circuit .....	59
3. VCF Resonance (Q) Control Voltage Mixing Circuit .....	59
4. VCA Control Voltage Mixing Circuit .....	60
<b>Other Circuits</b> .....	61
1. Sustain Control Circuit .....	61
2. Tuning Voltage Circuit .....	62
3. Preset Tone Setting Voltage Divider Circuit .....	63
<b>Tuning Method</b> .....	65

---

1107 OF 18-20

1107 OF 18-20

# PANEL CONSTRUCTION OF CS-50

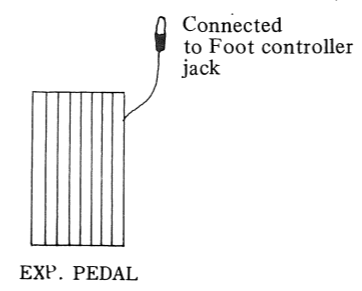
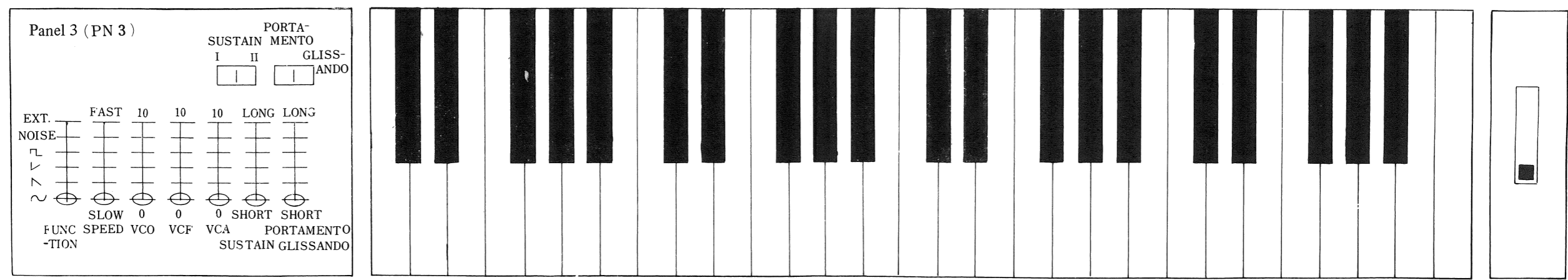
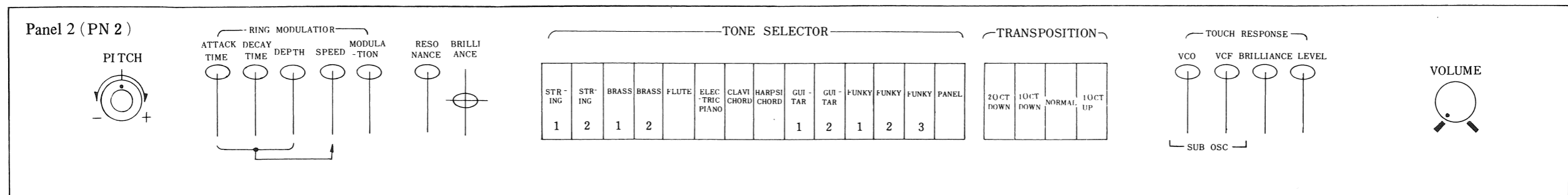
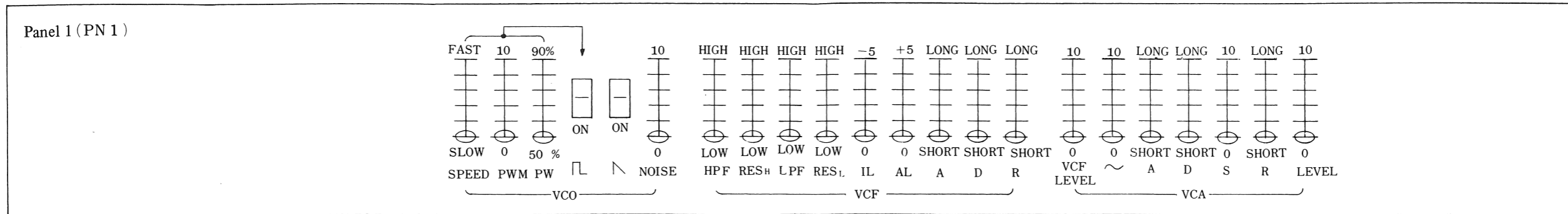
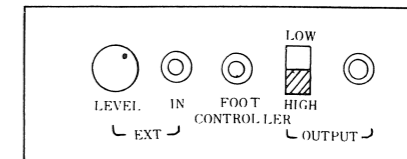

# PANEL CONSTRU

Panel 1 (PN 1)

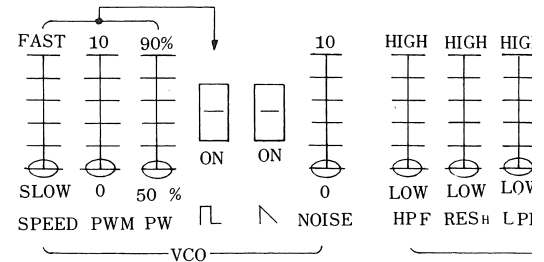

Panel 2 (PN 2)

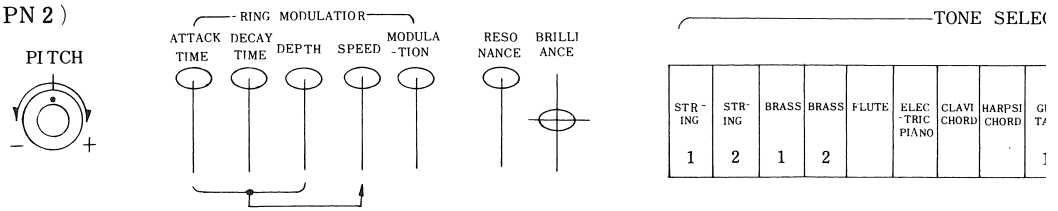

Panel 3 (PN 3)

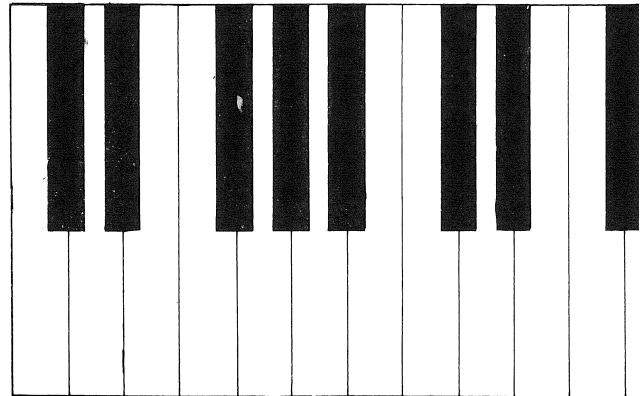
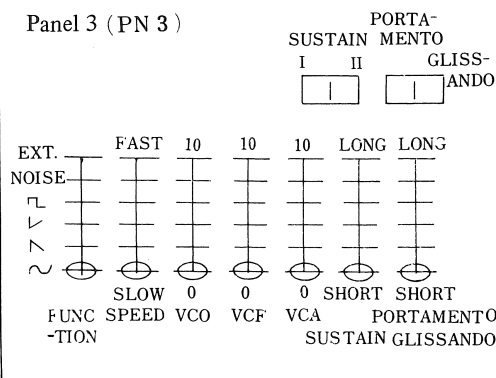

# INSTRUCTION OF CS-50

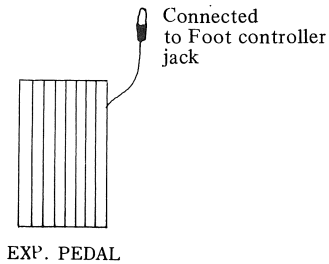
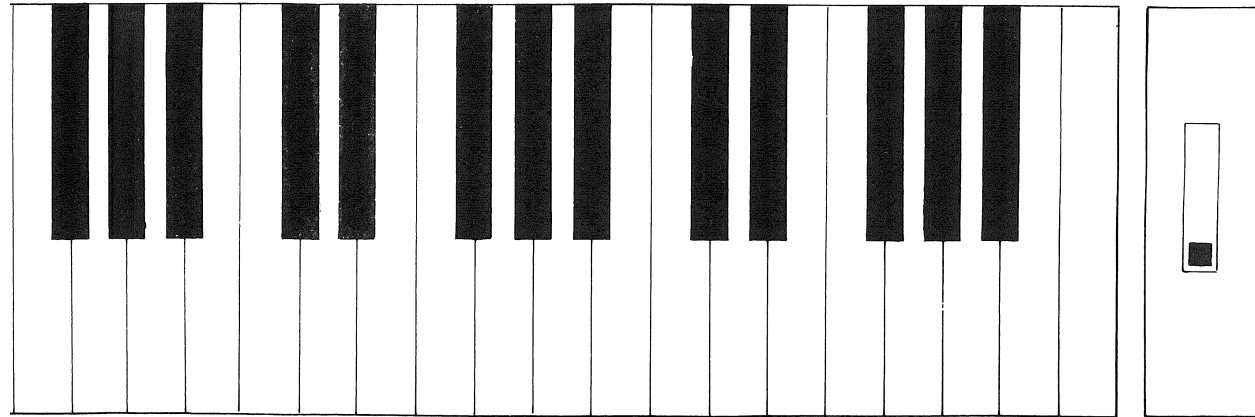
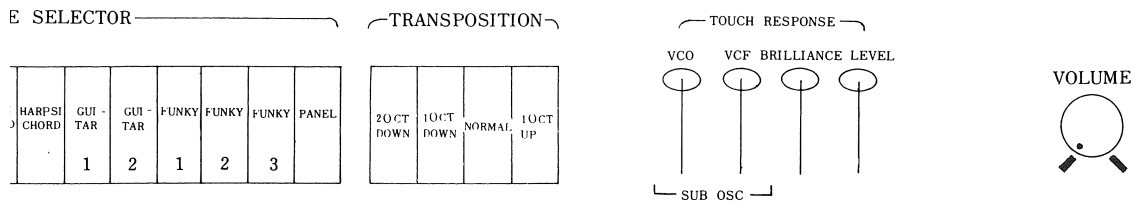
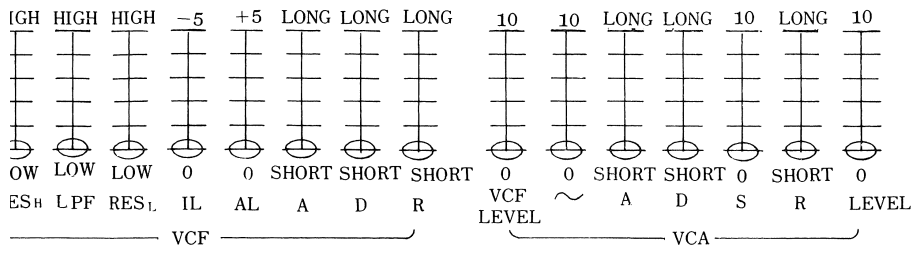
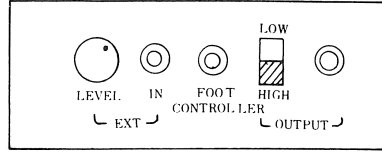



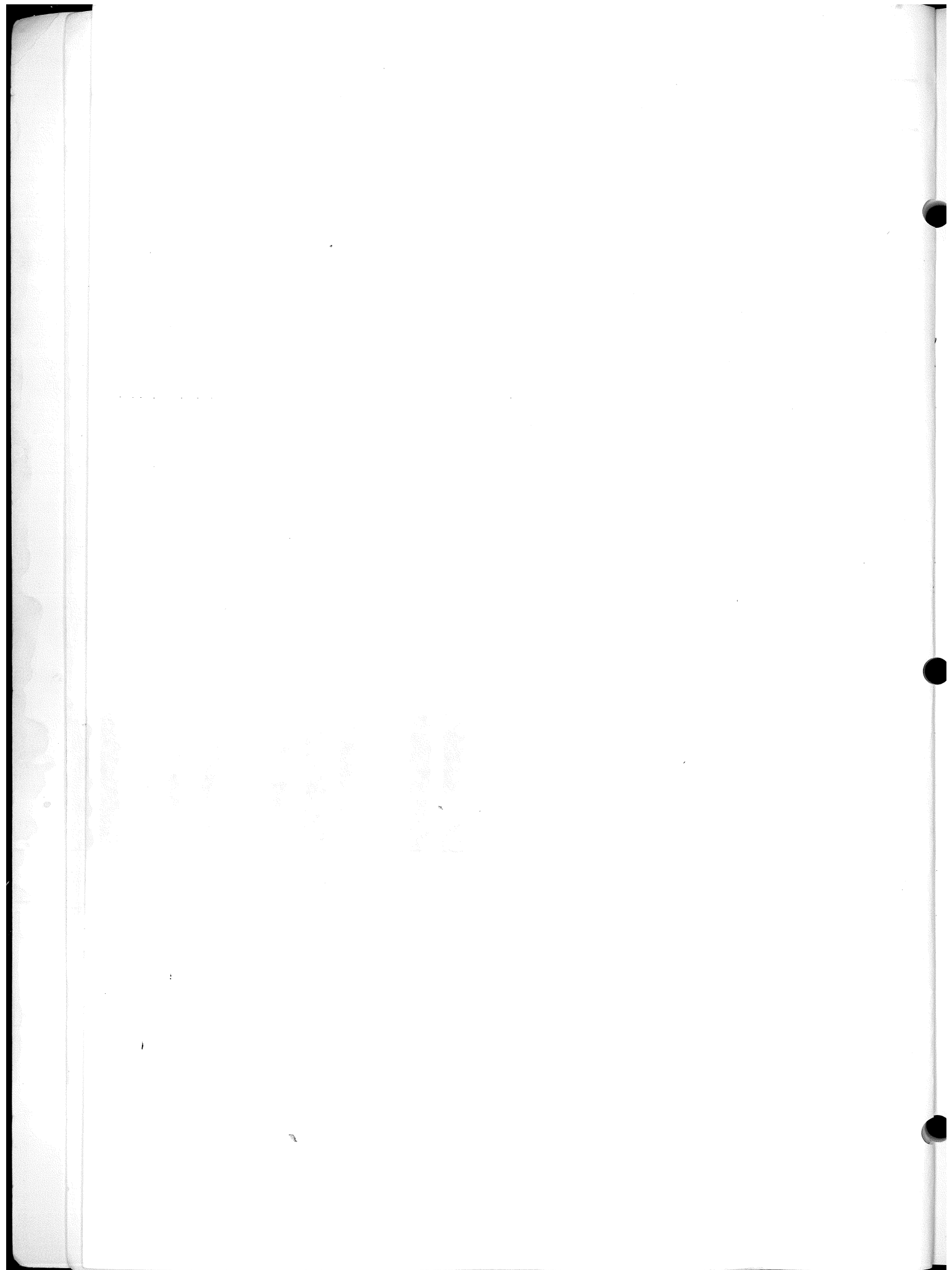

---

# INTRODUCTION

---

The CS series synthesizers are innovative synthesizer products with a number of unique features. In order to handle these products properly, the service engineer must fully understand not only the characteristics of each model, but also the principles of the synthesizer.

This manual contains detailed descriptions of the construction and operation of the various circuits, and the functions of the IC's used in them, for Model CS-50. Since each of the circuits employs digital technologies, it is essential to understand the fundamentals of digital technology before reading the manual. In order to service a CS, thorough mastery of this manual in combination with the Service Manual is recommended.

# FUNCTION OF PANEL LEVER

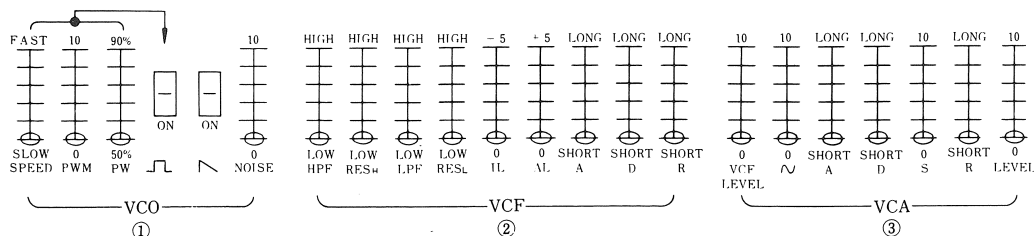

## [1] Panel 1

The controls illustrated above work only when the "PANEL" (green) switch of the Tone Selector switches on Panel 2 is ON. The Panel 1 controls allow setting of the factors which will produce the sounds one wants and create closer-to-natural tone color.

### ① VCO (Voltage Controlled Oscillator)

Selects the sound source waveshape best suited for the tone color to be created.

□ ..... Selects the square wave for the sound source.

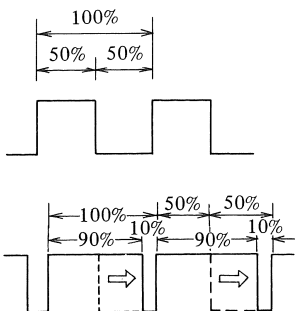

(Fig. A) Duty ratio of square wave

When the duty ratio (as illustrated at the left), indicates 50%, the waveshape is generally called the square wave. The signal includes the odd-numbered harmonics and is best for synthesizing tone colors like those of the clarinet.

For a waveshape with a larger duty ratio (as illustrated at the left), the signal also includes the even-numbered harmonics, and is best for synthesizing tone colors like those of the trumpet.

PW (Pulse Width) ..... This lever changes the duty ratio from 50% to 90%, allowing variations in the harmonic composition of the sound source.

PWM (Pulse Width Modulation) ..... This lever rhythmically modulate the pulse width up to  $\pm 40\%$  with the duty ratio set by the PW lever at the basic reference by an ultra-low frequency modulation signal.

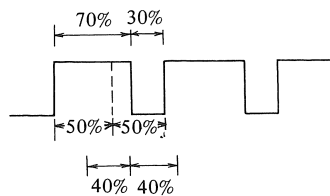

Duty ratio (70%) set by the pw lever

(Fig. B)

SPEED ..... This lever alters the PWM speed by changing the frequency of the modulation signal.

..... This lever selects the saw-tooth wave shape for the sound source. This wave shape contains the high-order harmonics of smaller amplitude than those of the square wave and is best for synthesizing tone colors like those of the violin, although its tone color is not bright.

NOISE ..... This lever selects the white noise which not only simulates the sound of wind or waves but also synthesizes the breathing noise of wind instruments such as the noisy flute, by mixing with the corresponding sound.

~ (Sine Wave shape) ..... This sine wave shape is fed directly into the VCA without passing through the VCF. Over a period of time the sound volume level will change.

② **VCF (Voltage-Controlled Filter)**

In conventional electronic organs, the cut-off frequency ( $f_c$ ) of the filter which determines the tone color is fixed, not variable. In the actual mechanical instruments, however, the tone color varies from moment to moment. More natural sounds can be simulated by controlling the voltage envelope with a VCF in which the  $f_c$  is shifted by the change in voltage.

• **HPF (High-Pass Filters)** ..... This filter passes signals with frequency component above the filter's cut-off frequency – and gradually rejects signals with frequency component below the cut-off point. The higher the lever is set, the higher the cut-off point ( $f_c$ ) will be shifted, giving more brilliant tone color.

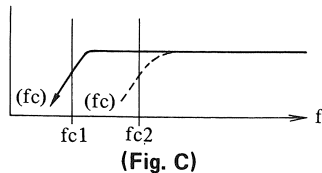

• **RESH (Resonance High)** ..... Adding resonance to a high pass filter causes the filter to emphasize a band of frequencies just at the cut-off point. Resonance is extremely important in the synthesizer filters. Almost every mechanical instrument has its own characteristic resonances, and in order to simulate close-to-natural sounds, this lever is raised: the higher the lever is set, the sharper the band at  $f_c$  will be emphasized.

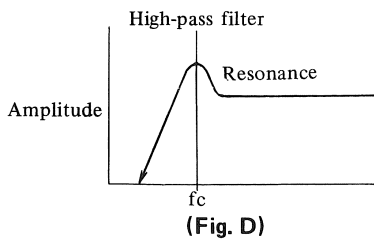

• **LPF (Low-Pass Filter)** ..... This filter rejects signals with frequency component above the  $f_c$ , in contrast to the HPF. The higher the lever is set, the higher the  $f_c$  will be shifted, thereby passing the higher frequency component of the signal.

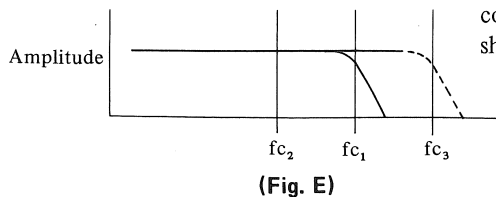

• **RESL (Resonance Low)** ..... Emphasizes sharply the frequency component at the  $f_c$  of the LPF, in the same way as the RESH.

• **Envelope for VCF (IL, AL, A, D, R)**

Changes from moment to moment both  $f_c$ 's of the high pass filter and the low pass filter with a voltage envelope, as illustrated, indicating the change of tone color ( $f_c$ ) with respect to time, within the time span from the beginning to the die-away of the sound.

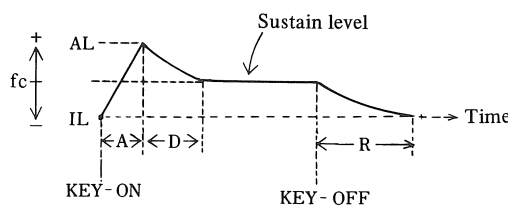

- IL (Initial Level) ..... This sets the starting point of the cut-off frequency ( $f_c$ ) of the VCF at the moment a key is depressed. The  $f_c$  rises from this level toward the sustaining level.
- AL (Attack Level) ..... Sets the highest level of the  $f_c$  for both the VCF-HPF and the VCF-LPF to rise after a key is depressed. The greater the difference is between the IL and the AL, the more pronounced the change of tone color from soft to brilliant.
- A (Attack Time) ..... Controls the time required to change the  $f_c$  from the IL to the AL. For instance, when A is long ( $f_c$  rising slowly), the tone color changes gradually from soft to brilliant, and the voltage envelope shows a gentle slope from the IL to the AL.
- D (Decay Time) ..... Controls the time span from the maximum  $f_c$  at the Attack Level (AL) to the  $f_c$  of constant condition (the key kept depressed: Sustain Level) of both the  $f_c$ 's of the VCF-HPF and VCF-LPF.
- R (Release Time) ..... Controls the time in which the  $f_c$  returns from the sustain level to IL from the moment that the key is released.

### ③ VCA (Voltage Controlled Amplifier)

Controls the amplitude of the signal. Each mechanical instrument has its own pattern of changes in sound intensity (loudness) during the rise, sustain and decay phases, and this is a very important factor in its total characteristic tone color. For instance, the sound of a piano rises rapidly when a key is depressed and dies away quickly when it is released; but if the damper pedal is pressed, the sound will be sustained long after releasing the key. Accordion sound rises fairly slowly.

In order to simulate the constantly changing volume of sound from the start to the die-away in the musical instrument, there are two ways of controlling the VCA gain: manual control with two levers (VCF and  $\sim$ ), and envelope control as same as the VCF.

#### Envelope for VCA (A, D, S, R)

Sets the time course of changes in loudness from the start to the die-away with the following four parameters:

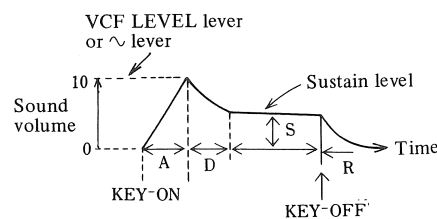

- A (Attack Time) ..... Determines the time span of loudness rising from zero to the peak level when a key is depressed.
- D (Decay Time) ..... Determines the time span of loudness falling from the peak level to the sustain level (see 25).
- S (Sustain Level) ..... Sets the loudness level to be sustained while the key is held down.
- R (Release Time, Sustain Time) .... Controls the time span of loudness falling from the sustain level to zero when the key is released.

## [II] PANEL 2

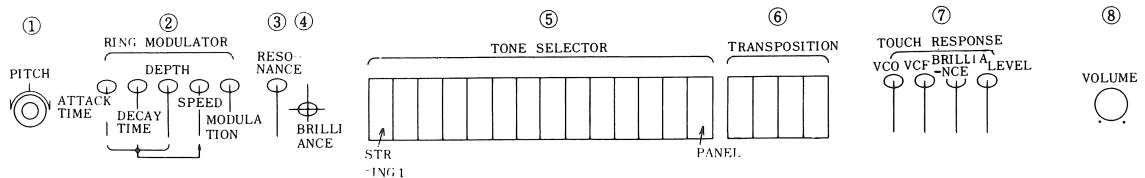

### 1. PITCH

Controls the pitch.

The pitch can be changed by plus or minus a half octave from the center click point (A3=443 Hz) with the coarse knob (outside) and +14, -11 Cent with the trifle control knob (inside).

### 2. RING MODULATOR

Provides a kind of amplitude modulation (AM), producing a very complex characteristic such as nasal sound, which contains high-frequency components free from the fundamental frequency, emphasizing beating sounds.

- MODULATION . . . . . Controls the mixing ratio of the ring-modulated signal to a non-modulated signal which by-passes the ring modulator, thus varying the depth of the ring modulation effect.
- SPEED . . . . . Sets the speed of the modulation signal.
- DEPTH . . . . . Controls the maximum beat speed controlled by Attack Time Lever and Decay Time Lever.
- ATTACH TIME . . . . . Controls the time span of the beat speed rising from the speed set by the SPEED lever to the maximum speed set by the DEPTH lever, when a key is depressed.
- DECAY TIME . . . . . Controls the time span of the speed falling from the maximum speed to the constant speed set by the SPEED lever, as set by SPEED lever.

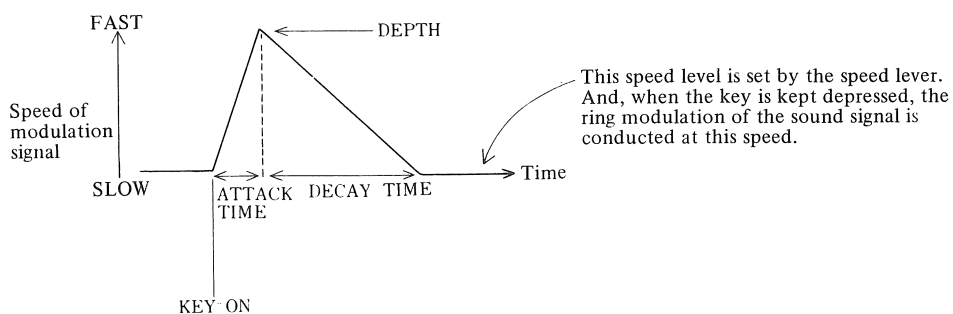

### 3. RESONANCE

Takes the resonance for the frequency band at the cut-off frequency, as in case of RESH and RESL emphasizing the sound of that frequency and producing a unique sound.

### 4. BRILLIANCE

When this lever is shifted toward MAX, the cut-off frequencies of HPF and LPF rise to increase the amplitude of the higher harmonics, resulting in the more brilliant sound. When shifted toward MIN, the higher harmonics are rejected, giving softer sound.

**5. TONE SELECTOR**

Selects the sound which has been preset to the tone color of the particular instrument. If none of the levers is depressed, the sound is automatically set to STRING I at the left end. If two or more tablet switches are depressed simultaneously, the lever (tone) farthest to the right is automatically selected. While the preset tone is used, the manual controls on Panel I are inoperative.

**6. TRANSPOSITION**

A switch lever to shift octave.

- 1 OCT UP ..... The keyboard scale shifts to  $C_3 \sim C_7$
- NORMAL ..... The keyboard scale shifts to  $C_2 \sim C_6$
- 1 OCT DOWN ..... The keyboard scale shifts to  $C_1 \sim C_5$
- 2 OCT DOWN ..... The keyboard scale shifts to  $C_0 \sim C_4$

When no lever of this switch is depressed, NORMAL is operative. If two or more levers are depressed, the lever farthest to the right is automatically operative.

**7. TOUCH RESPONSE**

The following parameters are controlled by the intensity (keyboard depth) of keyboard depression.

- LEVEL ..... The deeper the key is depressed, the louder the sound.
- BRILLIANCE ..... The deeper the key is depressed, the more brilliant the sound.
- VCF } .....
- VCO } ..... The deeper the key is depressed, the greater the effect of the sub-oscillator.

**8. VOLUME**

Controls the overall sound volume.

**[III] PANEL 3**

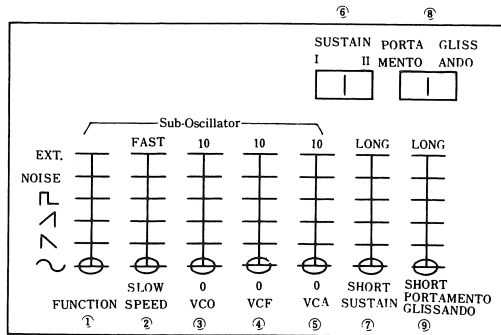

**SUB-OSCILLATOR**

**1. FUNCTION**

Selects one of the following six wave shapes for modulation signal.

- ..... (Sine Wave) Smooth modulation.
- ..... (Sawtooth Wave) Modulation with quick rise.
- ..... (Sawtooth Wave) Modulation with slow rise.
- ..... (Square Wave) Angular modulation.
- NOISE ..... Variable modulation with pink noise.
- EXT ..... Modulation signal derived not from the sub-oscillator but from an external audio signal (such as a rhythm box, record, tape, etc.), or an external oscillator other than the CS-50.

**2. SPEED**

When raised, speed of the vibrato, wah-wah and tremolo increases.

- ③ **VCO**  
Generally called vibrate, VCO produces pitch changes in accordance with voltage. The vibration effect grows deeper when the lever is raised.
- ④ **VCF**  
Generally called wah-wah, VCF changes the cut-off frequency according to voltage. By raising this lever, this effect becomes deeper.
- ⑤ **VCA**  
Generally called electronic tremolo, the sound signal amplitude is changed according to the modulation signal. The effect grows deeper when the lever is raised.
- ⑥ **SUSTAIN I & II SELECTOR SWITCH**  
When set to SUSTAIN I and several notes are released, each note decays independently. When set to SUSTAIN II, the decaying note is replaced by another note, when the key for the latter is depressed.
- ⑦ **SUSTAIN LEVER**  
Controls the decay time from releasing a key to die-away.
- ⑧ **PORTAMENTO & GLISSANDO SELECTOR SWITCH**  
The shift from the previously depressed note to the newly depressed note proceeds smoothly in PORTAMENTO, and in steps in GLISSANDO. If SUSTAIN II is depressed at the same time and the key is released during the shift, the interval continues to change while decaying.
- ⑨ **PORTAMENTO & GLISSANDO LEVER**  
Controls the speed at which the interval changes in the portamento or the glissando.

#### [IV] REAR PANEL

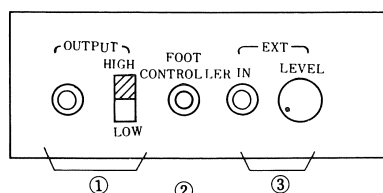

- ① **OUTPUT**  
Since the synthesizer includes neither power amplifier nor loudspeaker, the sound becomes audible only when the signal is fed from this terminal to an external amplifier and a speaker. The output level is 0dBm for HIGH, and -18dBm for LOW, when all the volume controls are turned fully clockwise and keys for four notes are depressed.
- ② **FOOT CONTROLLER**  
Connects the expression pedal for free volume control.
- ③ **EXT. IN**  
Input terminal of external signal for one of modulation signal for sub-oscillator effect. The signal level can be controlled by the level control.

#### [V] OTHERS

A headphone can be connected for monitoring to the HEADPHONE terminal, located on the bottom of the CS-50.



## CS-50 CIRCUIT BOARD CONTENTS

Circuit board	Main circuit	Other circuits
KAS	Key data producing circuit  Key voltage detecting circuit	Master clock ( $\phi$ ) oscillator KEY-ON signal buffer circuit Delay circuit Key-voltage ladder network circuit Key-voltage integrator and gate circuit Key-voltage buffer amplifier Glissando (or Portamento) operation control circuit
SH	Key-voltage sample hold circuit	Sustain mode switching circuit
M1	Voltage controlled oscillator (VCO) Wave shaper converter circuit Voltage controlled filter circuit (VCF) Voltage controlled amplifier circuit (VCA)	Transposition switching circuit Selection gate circuit of sound source wave shape Control voltage generator (VCF-EG) Control voltage generator (VCA-EG)
M2 to M4	— do. —	— do. —
PRA	Buffer amplifier circuit for MIX use Expression circuit Output amplifier circuit Headphone amplifier circuit	Ring modulator circuit
SUB	Sub-oscillator, PWM oscillator Level control circuit for modulation signal of Sub-oscillator Buffer amplifier for touch response detected signal.	
R7	Mixing circuit for control voltage.	
T71,T72	Voltage distributing circuit for pre-set tone use	*DC supply (+10V).

\*Incorporated in T71 sheet

# BASIC BLOCK DIAGRAM OF CS

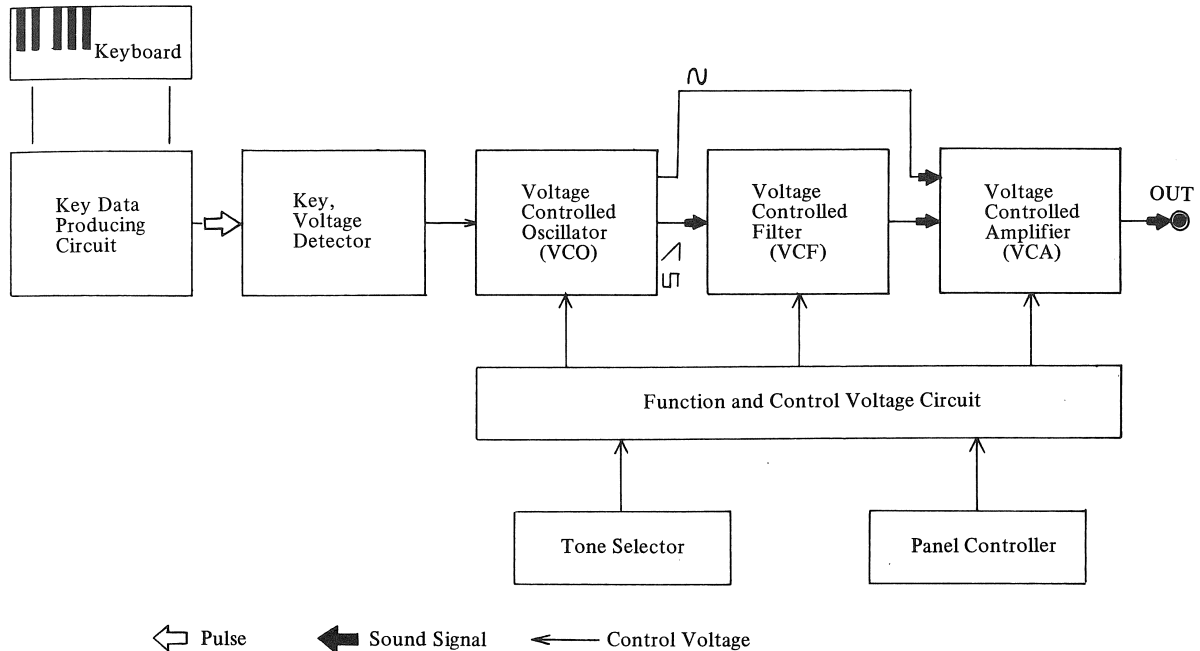

Keyboard	When a key is depressed (ON), the key data producing circuit is activated.
Key Data Producing Circuit	The note and the octave for the depressed key are encoded into digital data of 4 bits and 3 bits, respectively, and output up to four notes sequentially on a time-sharing basis.
Key Voltage Detector	One of the key voltages previously set between 0.25 V DC and 4 V DC is detected and is output by opening the gate on the basis of the digital data from the key data producing circuit, corresponding to the depressed key.
Voltage Controlled Oscillator (VCO)	Generates the sawtooth wave having an interval corresponding to the key voltage from the above-mentioned detector and provides a square and sine wave as the sound source on the basis of the sawtooth by feeding the latter into a wave shaper converter. The vibrato effect can be obtained by adding a manual control voltage or a modulation signal from sub-oscillator.
Voltage Controlled Filter (VCF)	The tone color can be varied in terms of time span by applying a sawtooth or square wave to the VCF. If the VCF is controlled by the modulation signal of the sub-oscillator or touch control signal, the wow-wow effect can be expected.
Voltage-Controlled Amplifier (VCA)	The time-dependent level changes such as rise and decay, which are characteristic parameters of mechanical instrument sound, can be closely simulated by feeding an envelope created by manually setting A (attack), D (decay), S (sustain time) and R (release time) controls in the VCA section of Panel I into the VCA, to shape the output signal of the VCF. Applying the alternative voltage through a sub-oscillator or touch control produces the tremolo-like level effect.
Function and Control Voltage Circuit	Produces, controls and switches the envelope, the manually set DC voltage, or the alternative voltage from the sub-oscillator or touch control, for controlling VCO, VCF and VCA.

# KEYBOARD

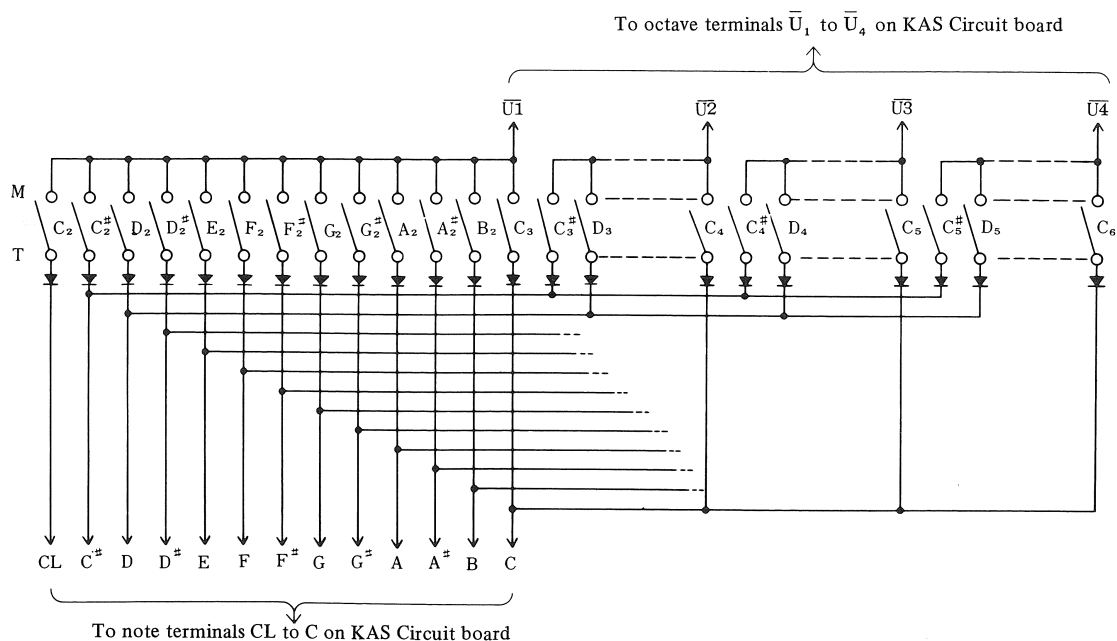

The key-switches on the keyboard are divided into 4 blocks corresponding to each octave. All the Make (M) contacts of the key switches in each block are connected together (the bar), to form four terminals,  $\bar{U}_1$ ,  $\bar{U}_2$ ,  $\bar{U}_3$  and  $\bar{U}_4$ , which are linked to the input terminals of the octave data encoder on the KAS (key assigner) circuit board, to produce the octave data by detecting to what octave the depressed note belongs. On the other hand, the transfer sides of the key switches for the same note in 4 blocks (e.g.  $C_2\#$ ,  $C_3\#$ ,  $C_4\#$  and  $C_5\#$ ) are connected together, except those of  $C_2$ . The lead wires for these 12 notes from  $C\#$  through C plus that for the lowest note  $C_2$  which is designated as  $C_L$  are linked to  $C_L$  to C terminals on the KAS circuit board to encode what note is being depressed. Thus, if a key switch is depressed, the particular circuits are closed to encode the octave data (3 bits) and the note data (4 bits) for that note in the key data producing circuit.

# KEY DATA PRODUCING (ENCODING) CIRCUIT

## KEY DATA PRODUCING (ENCODING) CIRCUIT

When a key is depressed, the corresponding octave terminal (one of  $\bar{U}_1$  to  $\bar{U}_4$ ) and note terminal (one of  $C_L$ ,  $C\#$  to  $C$ ) are connected, and 3-bits octave data and 4-bits note data are provided (7 bits in all). In Model CS-50, up to four notes can be sounded simultaneously, and the data for four notes are encoded and output sequentially on a time-sharing basis. The ON/OFF data signals of each key are also detected and produced.

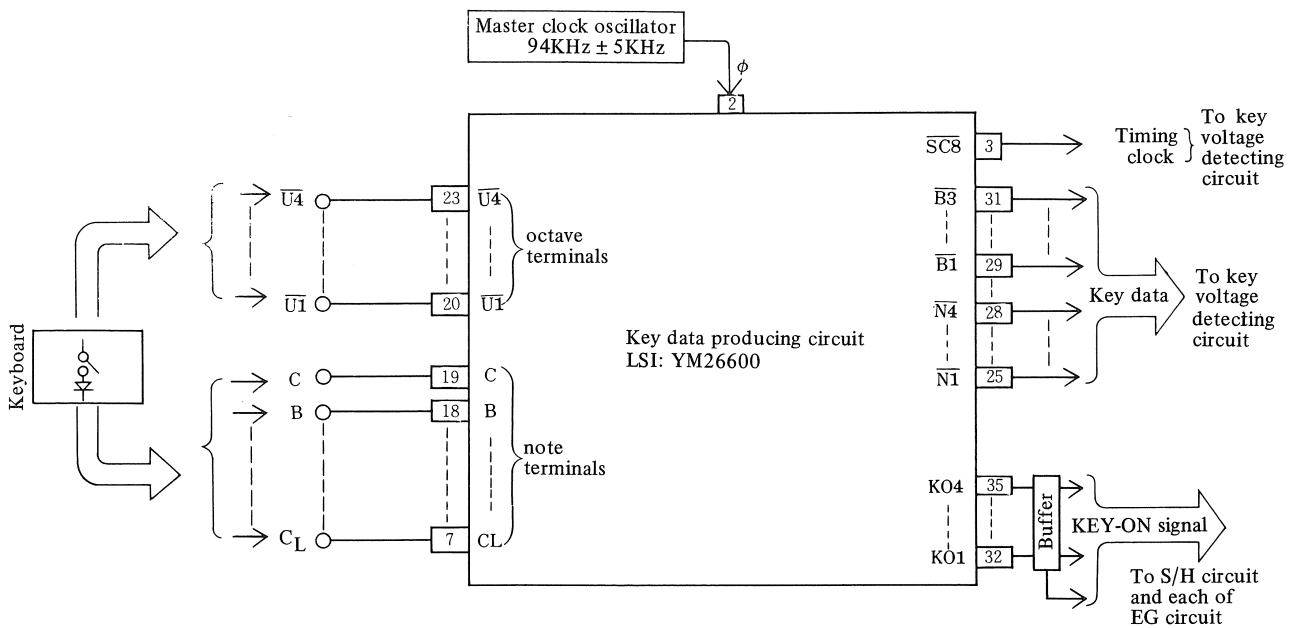
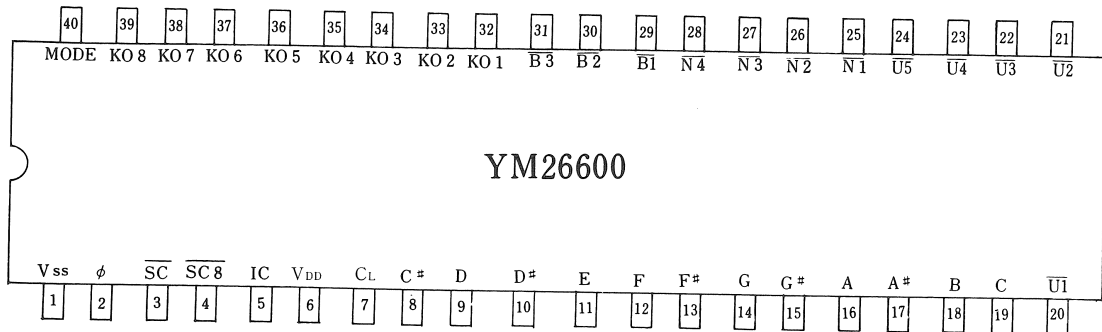

Fig. 2 Basic Construction of Key Data Producing Circuit

The key data producing circuit consists of an IC (YM 26600) and a master clock oscillator which operates the LSI (YM 26600) as shown in Fig. 1.

● PIN TERMINAL DESCRIPTION OF LSI (YM26600)



PIN	Name	Significance of terminal	PIN	Name	Significance of terminal
1	V <sub>SS</sub>	DC supply input, +8.5V	21	U <sub>2</sub>	* Octave terminal
2	φ	Master clock pulse input (94 ±5kHz)	22	U <sub>3</sub>	
3	SC	Synchro clock pulse (1/9φ)	23	U <sub>4</sub>	
4	SC <sub>8</sub>	Clock pulse output at 1/8SC	24	U <sub>5</sub>	
5	IC	Initial clear	25	N <sub>1</sub>	Note code data output (4 bits)
6	V <sub>DD</sub>	DC supply input, -6.5V	26	N <sub>2</sub>	
7	CL		27	N <sub>3</sub>	
8	C <sup>#</sup>		28	N <sub>4</sub>	
9	D		29	B <sub>1</sub>	Octave code data output (3 bits)
10	D <sup>#</sup>		30	B <sub>2</sub>	
11	E		31	B <sub>3</sub>	
12	F		32	KO1	
13	F <sup>#</sup>	Note terminal	33	KO2	KEY-ON data output Note: available as a pronouncing mode switching input terminal
14	G		34	KO3	
15	G <sup>#</sup>	35	KO4		
16	A	36	KO5		
17	A <sup>#</sup>	37	KO6		
18	B	38	KO7		
19	C	39	KO8		
20	U <sub>1</sub>	40	MODE	Pronouncing mode switching input terminal (at -6.5V for 8 sounds, +8.5V for 7 sounds)	

[REFERENCE]

● TIMING CLOCK ( $\phi$ ,  $\overline{SC}$ ,  $\overline{SC8}$ )

The master clock pulse  $\phi$  is used for synchronizing the LSI operation and counter, and  $\overline{SC8}$  with speed slowed down (period extended 10 times) – which provides the interface between the digital circuit at the timing of master clock pulse and the analog circuit.

NOTE: The  $\overline{SC}$  timing pulse generated in this IC is not used for Model CS-50.

● DATA PROCESSING BASED ON TIME-SHARING

Dividing the time base into a number of specific units (channel; in this case, one cycle of the master clock pulse, 11  $\mu$ s), one data item is processed in a unit time, another data item in the next unit time, and so on. This method is called data processing based on time-sharing. For instance, the key coder in the LSI (YM266000) processes the key data in up to 8 channels (88 $\mu$ s) by time-sharing. When processing of the 8th channel is finished, the same processing starts again from the 1st channel. This is repeated sequentially until a new key is depressed.

While the notes produced by time-sharing are shifted from one to another, in actuality, all the notes are processed in just 88  $\mu$ s and the human ear perceives them as if produced simultaneously. Thus, up to 8 notes can be produced “at once.”

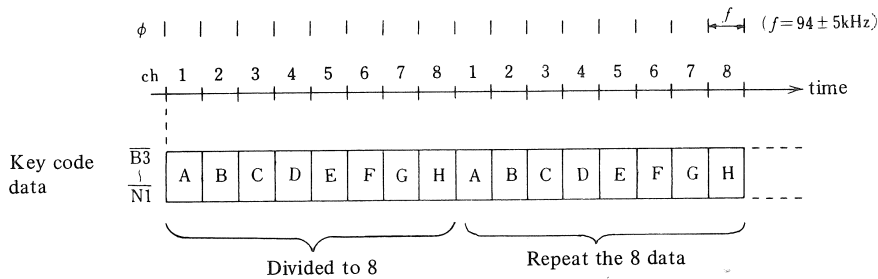

● CONTROL OF PRODUCED NOTES

Notes Terminal	8	7	6	5	4	3	2	1
MODE	1	0	0	0	0	0	0	0
KO8	×	1	0	0	0	0	0	0
KO7	×	×	1	0	0	0	0	0
KO6	×	×	×	1	0	0	0	0
KO5	×	×	×	×	1	0	0	0
KO4	×	×	×	×	×	1	0	0
KO3	×	×	×	×	×	×	1	0
KO2	×	×	×	×	×	×	×	1
KO1	×	×	×	×	×	×	×	×

"0" = +8.5V "1" = -6.5V

In this LSI, the number of sounds (note) to be produced simultaneously can be varied from 1 to 8, as desired. This manual describes the circuit producing 4 notes used for Model CS-50. To make the LSI produce 4 notes, set terminals MODE, KO6 to KO8 to +8.5V, and KO5 to 6.5V. This controls the LSI so that the new key data is not put into the memory for the timing of channels 5 through 8, thus limiting the key code data to 4 notes. To set the number of notes to another value, control the MODE and KO1 to KO8 terminals as shown in the table at left.

NOTE: The KO1 to KO8 terminals designated as "0" or "1" are used as input terminals for mode switching control voltage, and those designated as "X" are for output terminals for KEY-ON signal.

● OPERATIONAL PRINCIPLE OF KEY DATA PRODUCING CIRCUIT.

The IC (YM26600) is functionally divided into the KEY CODER section to produce key code data representing the depressed key and the KEY ASSIGNER section which stores the key codes for up to 4 notes in the memory (shift register) and outputs them sequentially. The operation of the IC (YM26600) will be described below.

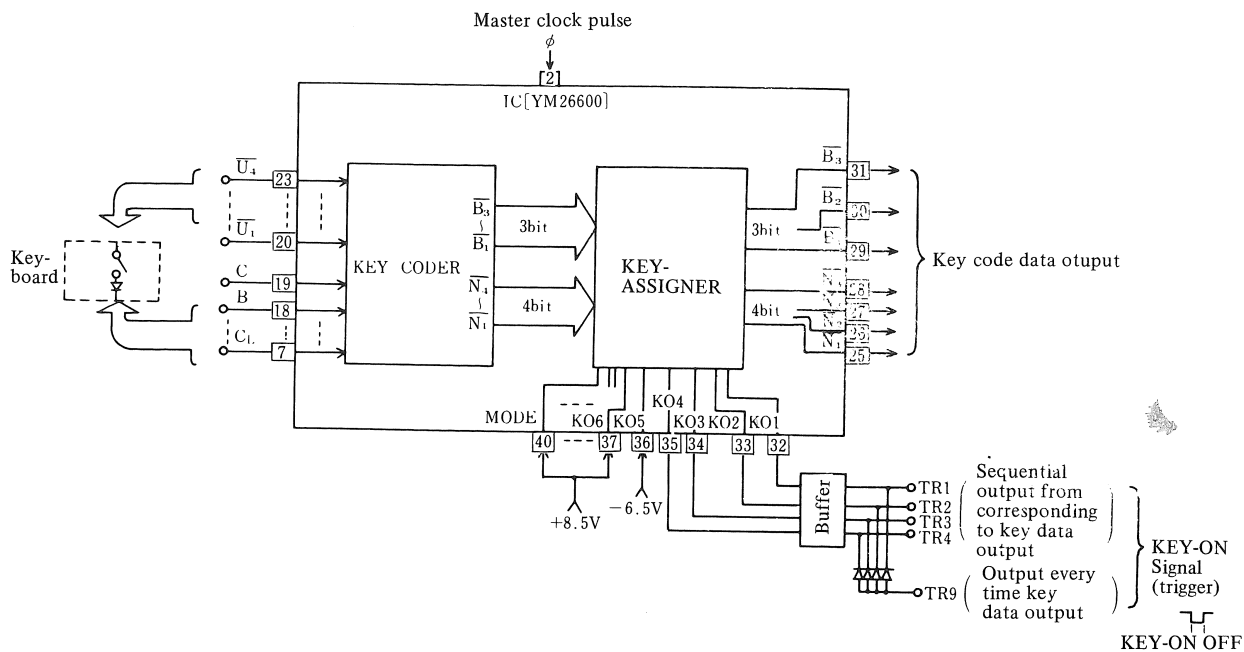

Fig. 2 Basic Circuit of IC (YM26600)

● KEY CODER

When a given key on the keyboard is depressed, the octave terminal ( $\bar{U}_1$  to  $\bar{U}_4$ ) and the note terminal ( $C_L$ ,  $C^\#$  to  $C$ ) corresponding to the key are closed, to output the octave data and the note data, respectively.

The Key code consists of 7 bits: 3 bits  $\bar{B}_1$ ,  $\bar{B}_2$ ,  $\bar{B}_3$  for the octave code data and 4 bits  $\bar{N}_1$ ,  $\bar{N}_2$ ,  $\bar{N}_3$ ,  $\bar{N}_4$  for the note code data. The digital data table for the keys are shown below.

OCTAVE CODE DATA

Input Output	$\bar{U}_1$ ( $C_2$ )	$\bar{U}_2$ ( $C_2^\# \sim C_3$ )	$\bar{U}_3$ ( $C_3^\# \sim C_4$ )	$\bar{U}_4$ ( $C_4^\# \sim C_5$ )	$\bar{U}_5$ ( $C_5^\# \sim C_6$ )
$\bar{B}_3$	1	1	1	0	0
$\bar{B}_2$	1	0	0	1	1
$\bar{B}_1$	0	1	0	1	0

NOTE DATA CODE

Input Output	$C^\#$	D	D $^\#$	E	F	F $^\#$	G	G $^\#$	A	A $^\#$	B	C
$\bar{N}_4$	1	1	1	1	1	1	0	0	0	0	0	0
$\bar{N}_3$	1	1	1	0	0	0	1	1	1	0	0	0
$\bar{N}_2$	1	1	0	1	1	0	1	1	0	1	1	0
$\bar{N}_1$	1	0	1	1	0	1	1	0	1	1	0	1

Table-1 Code Table

(e.g. 1) When C4 key is depressed.

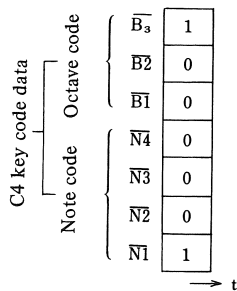

(e.g. 2) When E5 key is depressed.

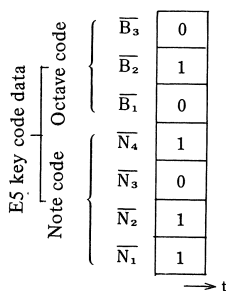

(e.g. 3) When C2 key is depressed.

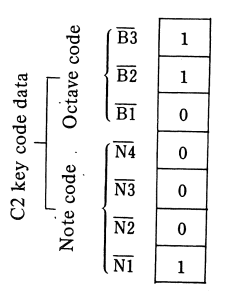





● OUTPUT TIMING CHART FOR KEY CODER

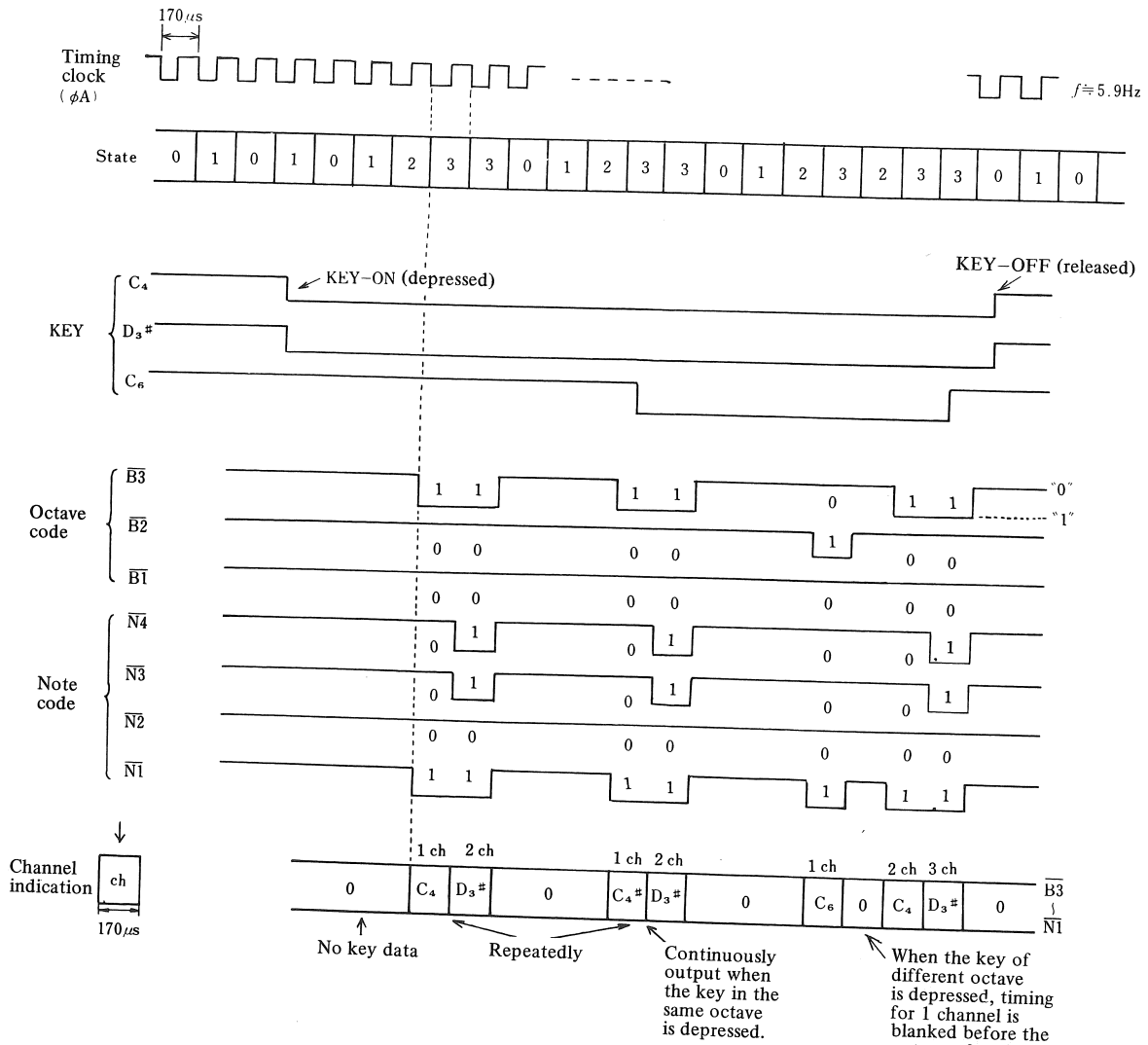

Since the same number of key code data as depressed are output in this timing, the recurrent period may be varied.

● KEY-ASSIGNER

In the key-assigner, the key data encoded by the key coder are taken in the order in which they are output, and are assigned to four VCO's on the basis of its decision as to which VCO the particular note is to be assigned to.

## [OPERATIONAL PRINCIPLE OF KEY ASSIGNER]

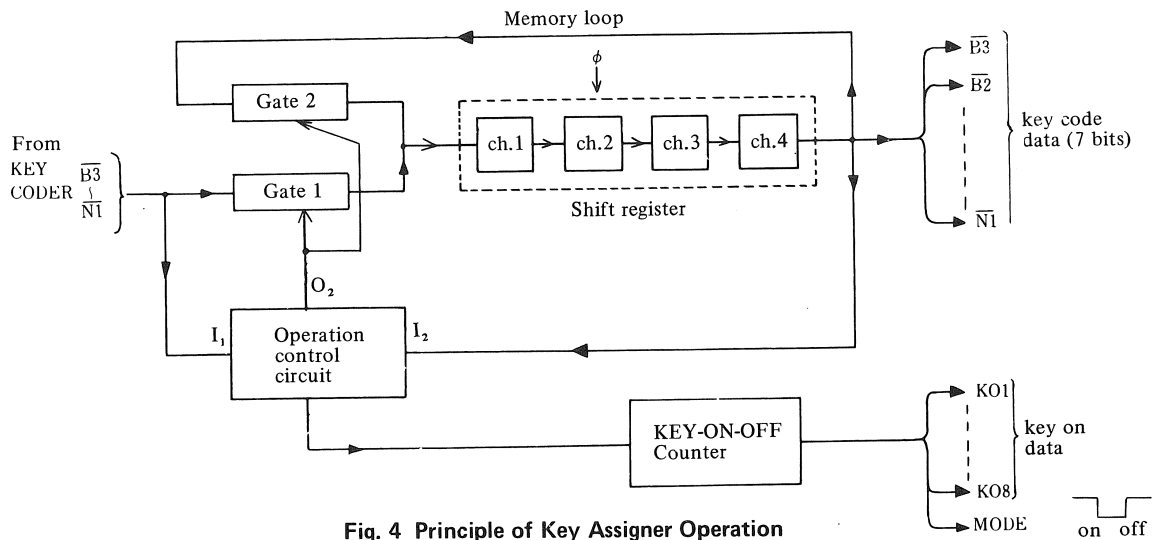

Fig. 4 Principle of Key Assigner Operation

As shown in Fig. 4, the key assigner comprises a shift register consisting of four-staged memory circuits, two gates to take in the key code data, a gate control circuit to control the gates depending upon whether the key for the particular key code data is newly depressed, has been kept depressed or has just been released, and a key ON/OFF counter which outputs the key ON/OFF data (key-on voltage) after detecting whether the data taken into the shift register is actually keyed on or off.

## [DETAILED OPERATION]

- **Gate Control Circuit**

This circuit receives the key code data from the key coder and that from the shift register, and compares them as described below to control Gate 1 and Gate 2.

- **Power Switch Turned ON, Key Not Depressed**

When the power switch is turned ON, the key code data for depressing the  $C_4$ -key is automatically generated in the IC and memorized in the shift register, to be shifted at the timing of the master clock pulse (94 kHz) and fed to the output terminals  $\bar{N}1$  through  $\bar{B}3$ , as well as to Gate 2 and  $I_2$ . But no key code data is supplied to  $I_1$  from the key coder, unless a key is actually depressed. The gate control circuit compares  $I_1$  with  $I_2$  to decide whether any key is depressed or not, and outputs the gate control data to turn Gate 2 on from  $O_2$ .

This closes the input-output of the shift register through Gate 2, and the shift register continues to shift the same data and to output it at  $\bar{N}1$  to  $\bar{B}3$ .

Operation of Shift Register with Gate 2 on.

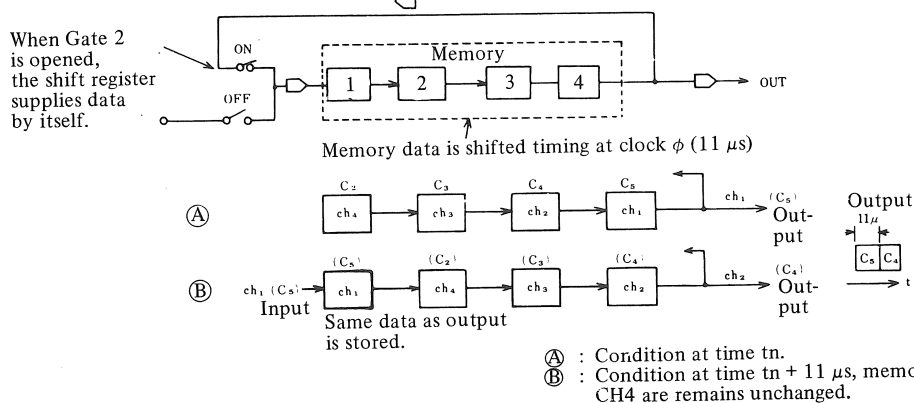

However, in this case, no key code data is input to the gate control circuit since no key is depressed. For this reason, the signal to give the key-on data is not supplied to the key on-off counter, incapacitating the subsequent sample hold circuit and VCA and producing no sound.

With channels 1 to 4 assigned for each timing of shift as illustrated, when a key is depressed the key code data for that note is stored in channel 1, and at the same time identical data are memorized in the other empty channels. If two keys, say  $C_3$  and  $G_3$ , are depressed simultaneously, the key code data for  $C_3$  is stored in channel 1, and that for  $G_3$  in channels 2 to 4. That is, the key code data for the last-depressed key is memorized in the empty channels.

- **Depressing a New Key**

When a new key is depressed, the key data for that note is output from the key coder to  $I_1$ , and compared with the data from shift register on  $I_2$ . If the consecutive outputs of shift register from 4 channels ( $11 \mu s$  per channel) include a code data which is not equal to the code data corresponding to the depressed key and to which the corresponding key is not depressed, Gate 1 is turned ON only during the channel ( $11 \mu s$ ) containing the said data to take in and memorize the new data in this channel, while the data previous stored in that channel is erased. When the storage ( $11 \mu s$ ) is finished, Gate 1 is turned OFF and Gate 2 is turned ON to continue shifting. If the key is kept depressed under this state, the key-on data is output through the key on-off counter, allowing to open the gate.

- **Keeping a Key Depressed**

If a key is kept depressed, the key coder continuously outputs the corresponding key code data, while the shift register in the key assigner also continuously outputs the data through Gate 2 once the storage work is finished. Thus, if two data coincide and the key is kept depressed, the Gate 2 is turned on to continue shifting and giving the key output on data.

Operation of Shift Register with Gate 1

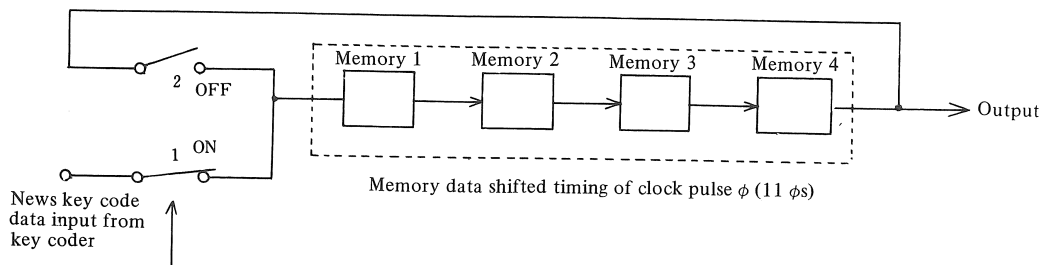

Operating control circuit determines the timing when the Gate 1 is ON. When it is ON, the Gate 1 accepts the data from Key Coder and put it in memory. Therefore, the new data is put in the channel selected at the time when the Gate 1 is ON. When the data is put in other channels, the Gate 2 is keyed ON.

- **KEY-ON Signal**

For detecting the key-on signal, the key ON/OFF counter is set in synchronization with timing of the key data control circuit turning Gate 1 ON (that is, when a new key code data is stored), and "1" signal is output from terminals KO1, KO2, KO3, ..., sequentially, until the key-OFF is detected.

## ● TIMING CHART OF KEY ASSIGNER OUTPUT

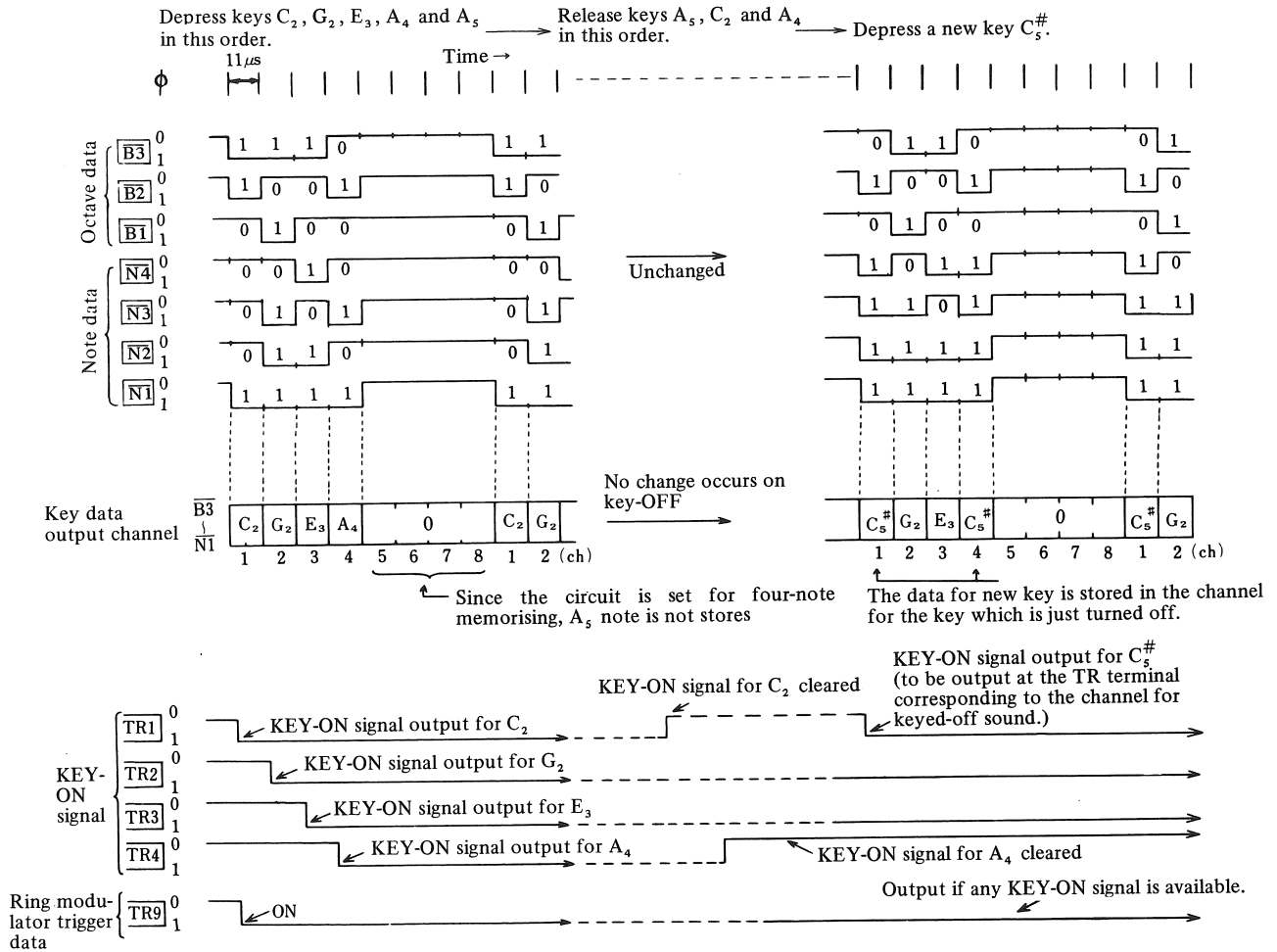

# KEY VOLTAGE DETECTING CIRCUIT

## ● BASIC CONSTRUCTION OF KEY VOLTAGE DETECTING CIRCUIT

The key voltage detecting circuit detects the analog DC voltage corresponding to the key on the keyboard (that is, key voltage) on the basis of key data which are supplied sequentially on the basis of time-sharing.

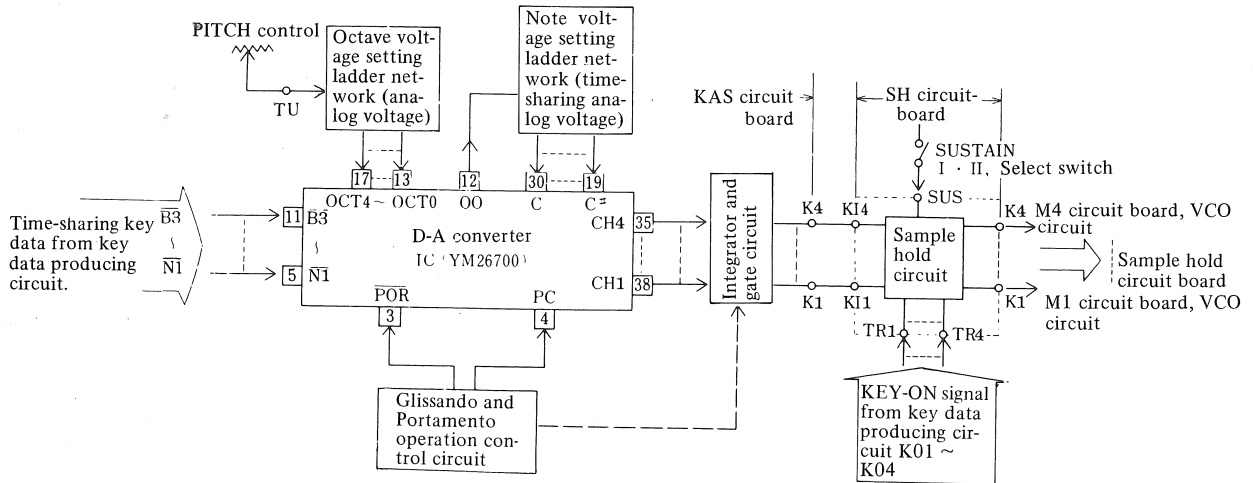

(fig-1)

As shown in fig-1, the circuit consists of:

- (1) D - A converter (digital to analog)
- (2) Glissando & portamento operating circuit
- (3) Sample hold circuit
- (4) Sustain mode selector circuit

## ● PIN TERMINAL DESCRIPTION OF LSI (YM26700)

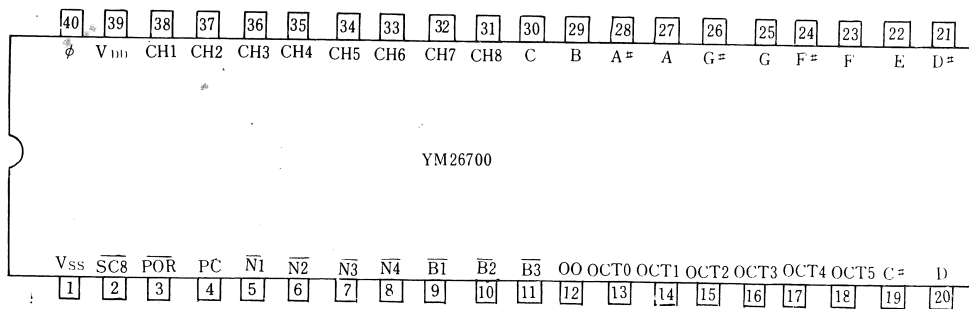

PIN	Name	Significance of terminal	PIN	Name	Significance of terminal
1	V <sub>SS</sub>	DC supply input, +8.5V	21	D#	*
2	$\overline{SC8}$		22	E	
3	$\overline{POR}$	Glissando control (Functionable at +8.5V) (Portamento) Clock pulse input for Glissando operation (Portamento)	23	F	
4	PC		34	F#	
5	$\overline{N1}$	Note code data input	25	G	Note voltage input
6	$\overline{N3}$		26	G#	
7	$\overline{N3}$		27	A	
8	$\overline{N4}$		28	A#	
9	$\overline{B1}$	Octave code data input	29	B	
10	$\overline{B2}$		30	C	
11	$\overline{B3}$	Octave voltage output (8ch-time sharing) Note) Time span of 1 ch is 1/9 $\phi$ .)	31	CH8	
12	OO		32	CH7	
13	OCT0		33	CH6	Key voltage output.
14	OCT1		34	CH5	
15	OCT2	Octave voltage input Oct5: not used	35	CH4	(CH8 to CH5: not used)
16	OCT4		36	CH3	
17	OCT4		37	CH2	
18	OCT5		38	CH1	
19	C#	*	39	VDD	DC supply input -6.5V Master clock pulse input
20	D		40	$\phi$	

● **TIMING CLOCK ( $\phi$ ,  $\overline{SC}$ ,  $\overline{SC8}$ )**

In this IC (YM26700),  $\phi$  is divided into 9 to produce  $\overline{SC}$  clock.

The key code data fed from the key data producing circuit (LSI: YM26600) at the channel time  $\phi$  is converted to  $\overline{SC}$  channel time to detect the key voltage.

The period of  $\overline{SC}$  is further divided by 8 to obtain  $\overline{SC8}$  timing clock. This represents the first channel time of output data at the timing of  $\overline{SC}$  clock for synchronization with the first channel.

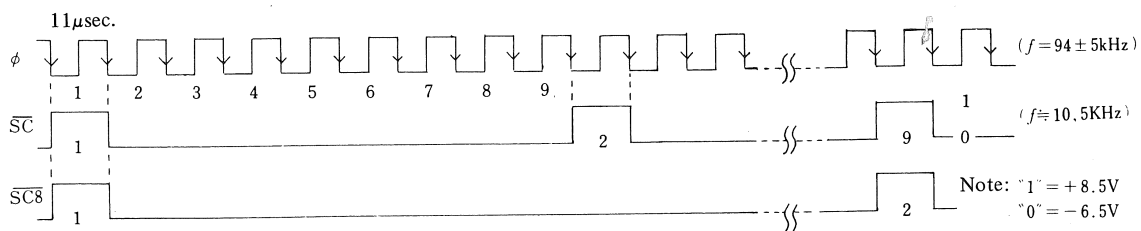

# OPERATIONAL PRINCIPLE I OF KEY VOLTAGE DETECTING CIRCUIT

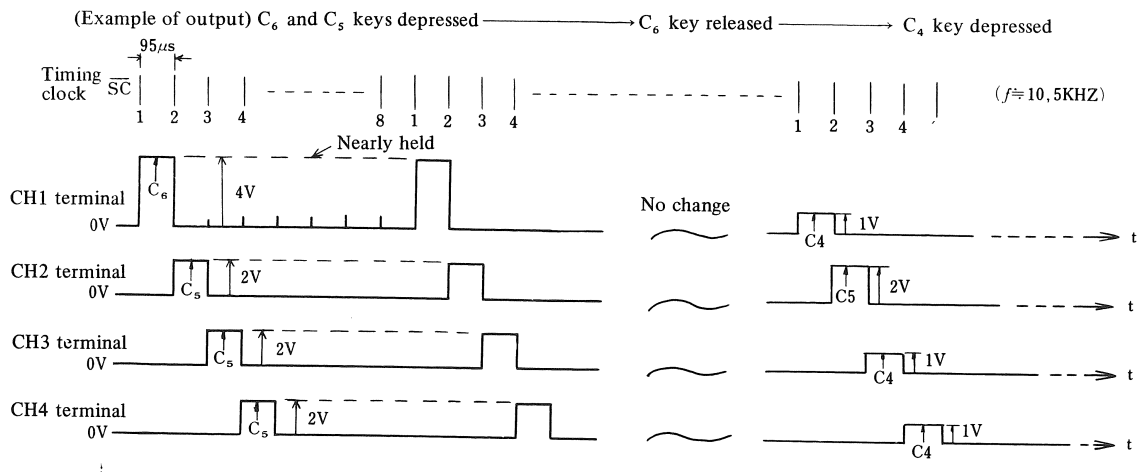
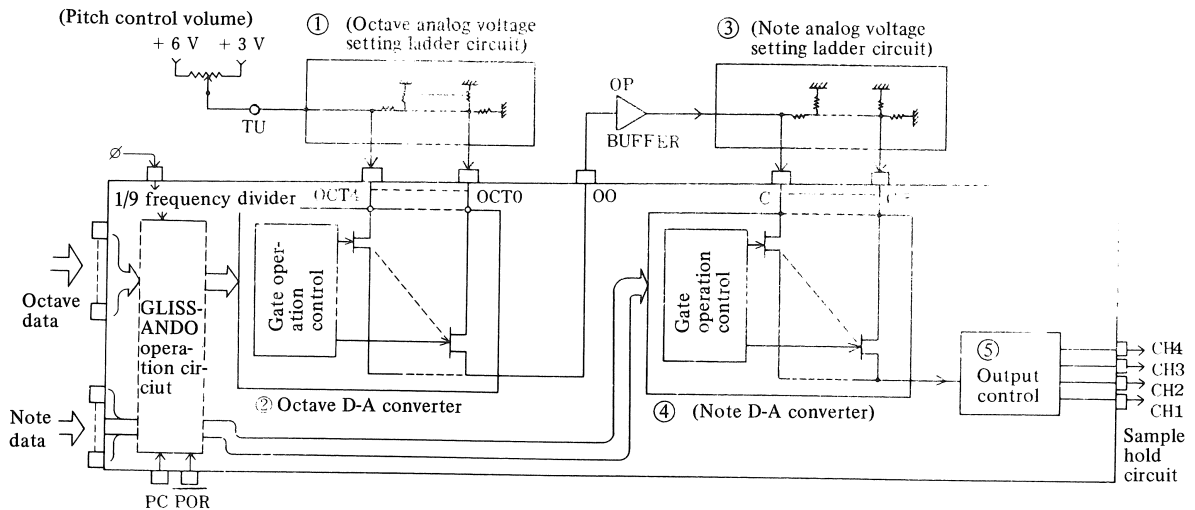

NOTE: The output voltage is integrated by the subsequent circuit and the stray capacitance, providing a nearly held voltage.

● **D-A CONVERTER**

1. **Ladder Network: to Set Octave Voltage (Analog)**

The fundamental voltage (3 to 6V), which can be varied by the pitch control, is applied to the ladder network comprising a number of resistors connected so as to form a ladder and divided exponentially to provide the resultant voltages to the inputs of D-A converter gate. The five voltage values correspond to octaves as shown in the table below. When the pitch control is set at the mid-point, 4V is applied to the TU terminal and 440 Hz can be obtained at note A<sub>3</sub>.

Terminal	OCT 4 (C <sub>6</sub> ~C <sub>5</sub> <sup>#</sup> )	OCT 3 (C <sub>5</sub> ~C <sub>4</sub> <sup>#</sup> )	OCT 2 (C <sub>4</sub> ~C <sub>3</sub> <sup>#</sup> )	OCT 1 (C <sub>3</sub> ~C <sub>2</sub> <sup>#</sup> )	OCT 0 (C <sub>2</sub> )
Oct. voltage	4 V	2 V	1 V	0.5 V	0.25 V

2. **D-A Converter Circuit for Octave**

The octave data consisting of 3 bits,  $\overline{B1}$  to  $\overline{B3}$ , is directly input to the D-A converter without being affected by the GLISSANDO operation circuit when  $\overline{POR}$  terminal is at "0". The octave data turns ON the gate to which the octave voltage (analog) corresponding to the data is applied, thus converting the octave data (digital) to octave voltage (analog). Since the octave data are processed on the basis of time-sharing, when plural keys up to four are depressed, the corresponding gates are opened through time-sharing to output the octave voltage. The order is the same as that of depressing keys.

3. **Analog-Voltage Set Ladder Network for Note**

The octave voltage output from the D-A converter is applied to the note ladder network as fundamental voltage. In the note ladder network, the octave voltage is divided to establish the musical interval for 12 notes (C<sup>#</sup>, D, D<sup>#</sup>, ..., A<sup>#</sup>, B, C,) in an octave and the octave output is provided to the analog gate as in case of octave voltage to be selected by 4-bit note data  $\overline{N1}$  to  $\overline{N4}$  and output. While the note data are also processed on the time-sharing basis sequentially, its timing is slowed by a factor of 9 in comparison to the master clock  $\phi$  so that the subsequent sample holding with an integrator is available.

4. **Output Control Circuit**

The analog key voltage corresponding to each key output through the time-sharing is allocated to channels 1 to 4.

- When only a key is depressed, the same key data is output in all four channels consecutively.
- When two keys are depressed, the key voltage for the first-pressed key is output in Ch1, and that for the second key is given in Ch2 to Ch4 consecutively.
- Thus, the empty channels are always filled with the key voltage for the last-pressed key.
- If 4 keys are depressed, four key voltages are output in Ch1 to Ch4 in the order of depressing.

\*Refer to Example of Output on the preceding page.



## OPERATIONAL PRINCIPLE II OF KEY VOLTAGE DETECTING CIRCUIT

### • PORTAMENTO OPERATION

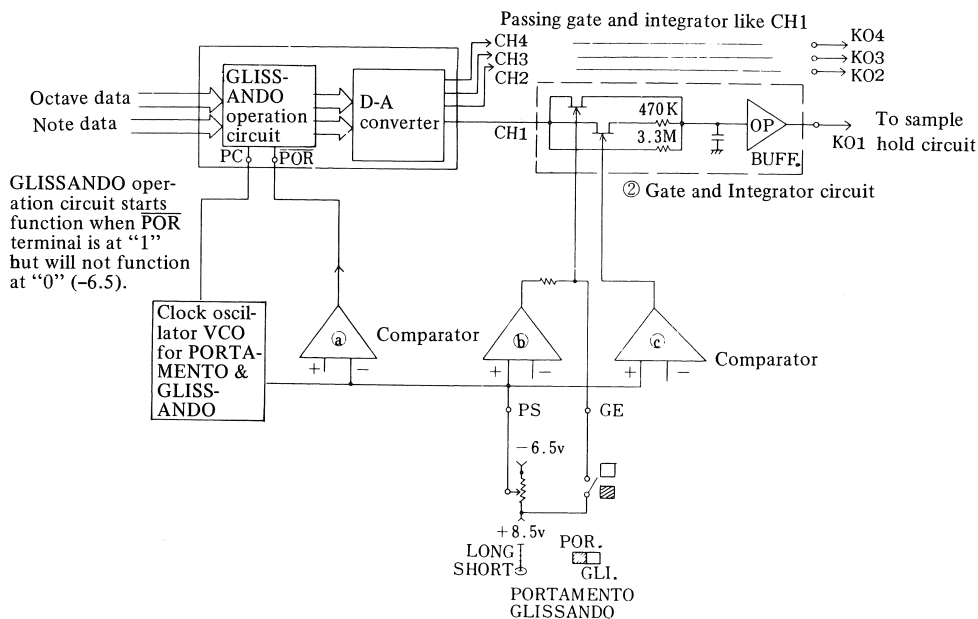

#### 1. Glissando Operation Circuit

When the PORTAMENTO/GLISSANDO selector switch on the panel is set to GLISSANDO, "1" data is provided at the POR terminal, allowing execution of the glissando operation. First, the key code data for the initially depressed key is applied to the glissando operation circuit. When the next key code data is input, the circuit compares it with the previous data to determine whether the glissando effect is to shift to the higher or lower side. At the same time, if the key code data corresponding to the musical interval between these two notes are sequentially counted and extracted from the first-depressed key and fed into the gate of D-A converter, the key voltage (musical interval) shifts sequentially stepwise. The counting rate can be changed by varying the voltage applied to the PC terminal, allowing to control the glissando rate: the higher the voltage is, the faster becomes the glissando rate.

#### 2. Integrating Gate Circuit

This circuit is for obtaining the portamento effect. The step voltage obtained by the glissando operation is integrated to provide the continuous shift the time constant of integration is determined by the time constant  $C \times R$  ( $470 \text{ k}\Omega$   $1 \mu\text{F}$ ).

In order to adjust the integrating rate to the rate of controlling the key code data in the glissando operation circuit, another integrating circuit having a different time constant is provided, and a gate is provided to each circuit. The comparators b and c control the gates so as to select the proper time constant.

The integrating circuit allows to sample-hold the key voltage output through time-sharing (which is in practice integrated by the stray capacitance in the D-A converter).

However, since the voltage is discharged through  $3.3 \text{ M}\Omega$  after key-off with the pitch lowered in the course of sustain time, a separate sample hold circuit is provided following the integrating circuit.

Output voltage of comparators  
Ⓐ Ⓑ Ⓒ vs. Time constant

PS voltage	Ⓐ	Ⓑ	Ⓒ
-1.72 ~ -6.5	1	0	0
3.81 ~ -1.72	1	0	1
7.14 ~ 3.81	1	1	1
8.5 ~ 7.14	0	1	1

Controlled by  
POR & GLI  
level

Controls  
GLISSANDO  
operation circuit

Controls  
integrating  
gate

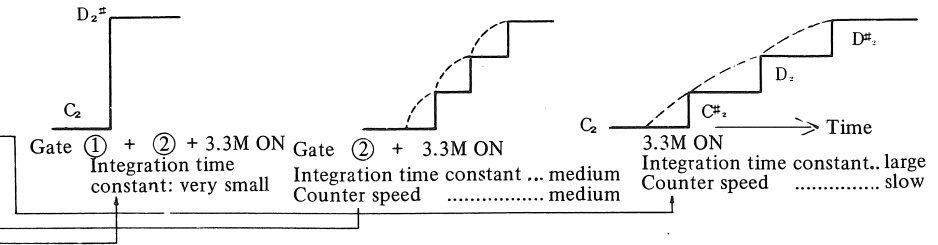

NOTE: "1" = +8.5V  
"0" = -6.5V

When the glissando tablet is ON, the gate 1 is constantly opened and the step voltage is output directly, resulting in the glissando effect.

## OPERATIONAL PRINCIPLE III OF KEY VOLTAGE DETECTING CIRCUIT

### • SAMPLE HOLD

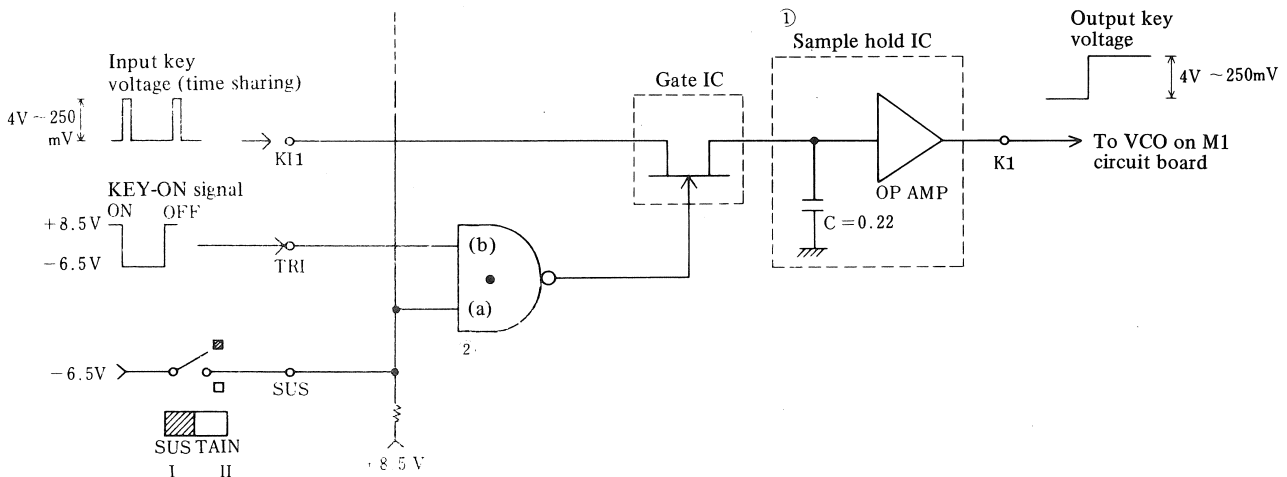

#### 1. Operation of Sample Hold Circuit

The key voltage integrated in the preceding gate circuit is held only insufficiently to keep the pitch during the sustain time since the impedance of gate circuit is not high enough. For this reason, a sample hold circuit consisting of FET gate, hold capacitor and buffer amplifier with very high input impedance is provided before the VCO so as to obtain the stable key voltage (DC).

#### 2. Operation of Gate Control

- At key-ON, the output of NAND circuit turns to "1", to open the FET gate.

Hence, the key voltage is integrated and held with the time constant determined by the characteristic resistance of FET and the hold capacitance.

At key-OFF, the FET gate turns off to provide very high impedance, and the discharge through the output side is prevented by the high impedance buffer amplifier using an operational amplifier, securing the highly stable key voltage, which is fed into the VCO III to oscillate the sound source.

#### • Sustain I & II and Gate Control Circuit

In the Model CS-50, it is possible to select two modes of sustain.

##### 1) Sustain I

This is the conventional sustain. When the depressed keys are released in this mode, all the notes die away keeping their respective notes (as shown in Fig. 1).

Sustain I

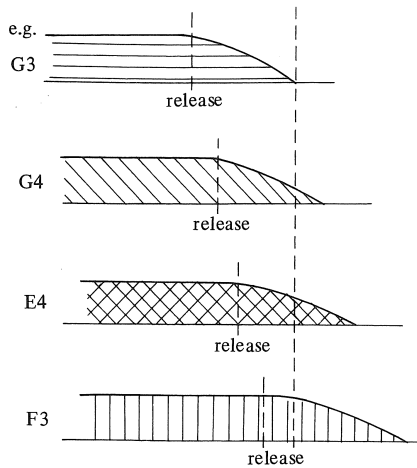

Fig. 1

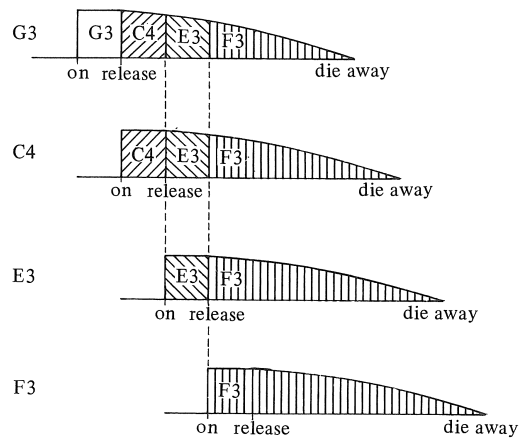

Fig. 2

2) Sustain II

If, while the note for the previously released key is decaying in the sustain time, another key is depressed, the note of decaying sound is replaced by that of newly depressed note. That is, as shown in Fig. 2, the keys separate by a few notes are pressed ON-OFF in arpeggio, the decaying note is altered every time a key is depressed. When three notes are decaying, all are replaced by the note for the last-depressed key.

The mechanism of sustain I & II may be understood from the relationship between the key-assigner output and the sample hold circuit.

The shift register in the key assigner stores and shifts the key code data for up to four notes. If all four keys are not depressed, the free output channel stores the same key code data as the last-depressed key.

In the sample hold circuit, in case of Sustain I, as (a) is at "1", (b) turns to "0" at the time of key-ON and the output of NAND circuit turns to "1". That is, the gate is opened only during key-ON, allowing to take the key voltage into the sample hold circuit. Accordingly, when the key is released to close the gate, the note for the depressed key decays without being affected by the change in the key voltage from the key assigner.

On the other hand, in case of Sustain II, (a) turns to "0" and the output of NAND circuit remains always "1", opening the gate irrespectively of the key ON data. This allows the key voltage for the last-depressed key to be taken up by the sample hold circuit, making all four oscillators of VCO III oscillate in the last-depressed note. If no other key is depressed after releasing the previously depressed key, this effect is not realized.

# VOLTAGE-CONTROLLED OSCILLATOR

## • BASIC CONFIGURATION OF VOLTAGE CONTROLLED OSCILLATOR

The voltage controlled oscillator (VCO) is an oscillator of which output frequency (interval frequency) is controlled by the voltage.

In this circuit, the sound of musical interval corresponding to the key board is produced by applying the key voltage detected by the key as the control voltage.

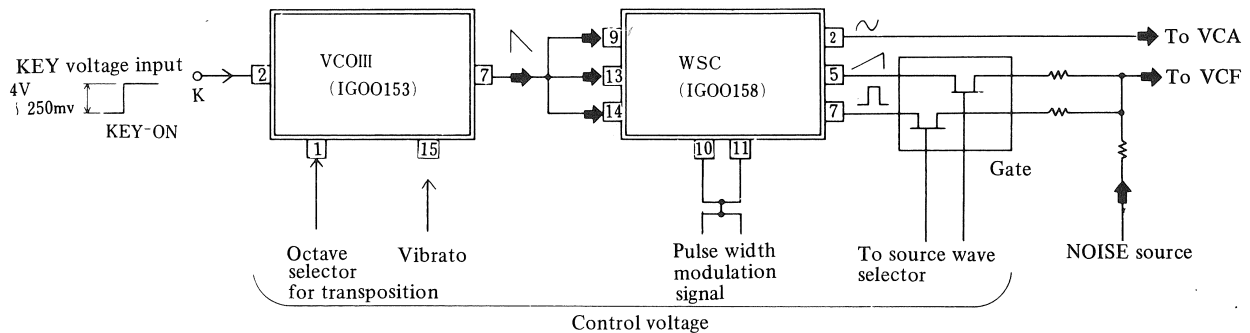
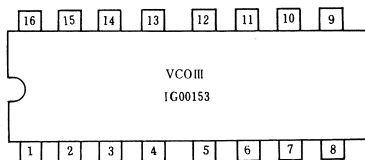

Fig. 4 Basic Construction of Sound Source Circuit

The oscillator circuit, in which the interval frequency corresponding to the keyboard and the sound source wave shape are formed, consists of voltage-controlled oscillator (VCO III) and wave shaper converter (WSC), all of which are voltage controlled. White noise is also used as the source signal. (See the section on Noise Generator.)

## • PIN TERMINAL DESCRIPTION OF VCO III (IG-00153)



1. Resistance terminal for transposition determination
2. Key voltage input
3. Off-set adjustment
4. Off-set adjustment
5. DC supply of  $-15V$
6. Phase compensation
7. Output
8. GND
9. Digital GND
10. Terminal for oscillation time constant (C.R)
11. Threshold voltage input for one-shot multi-vibrator ( $V_{th} \approx 10V$ )
12. Constant current supply terminal
13. Resistor connection terminal for constant current providing
14. Capacitor connection terminal for integrator time constant.
15. VIBRATO modulation signal input (centering around GND, 50 cent/1.5V)
16. DC supply of  $+15V$

## [ OPERATIONAL PRINCIPLE OF VCOIII (IG00153) ]

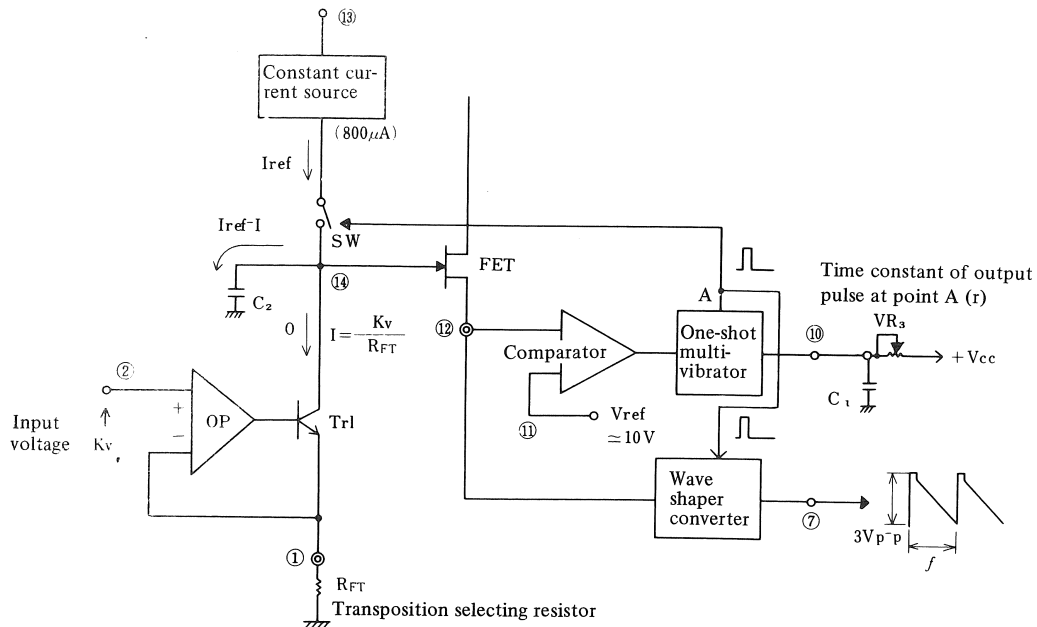

NOTE: Numbers in circle represent pin numbers of IC

When the voltage at ⑫ PIN is lower than that at ⑪ PIN ( $V_{ref} \approx 10V$ ), the comparator triggers the one-shot multi-vibrator to output switching-off pulse for a time determined by  $VR_3$  and  $C_1$ . The FET is biased so that it works as a buffer amplifier for ⑭ PIN.

If the switch SW is turned OFF while  $C_2$  is charged,  $C_2$  begins to discharge, lowering the voltage at ⑫ PIN gradually. When it becomes lower than the voltage at ⑪ PIN, the comparator actuates the one-shot multi-vibrator to deliver pulse which turns the switch ON.

As the switch turns ON,  $C_2$  is charged by the constant current ( $I_{ref}$ ) and the voltage at ⑫ PIN begins to rise. When the output of one-shot multi-vibrator decays, the switch turns OFF and  $C_2$  begins to discharge again. These steps are repeated.

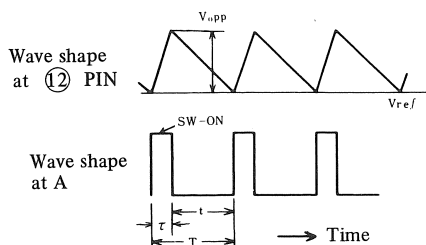

The wave shape at ⑫ PIN is superimposed to A pulse at the wave shaping circuit to obtain the output at ⑦ PIN.

This indicates that the frequency is controlled by  $C_2$ -voltage and the pulse duration of mono-stable multivibrator.

The maximum voltage at  $C_2$  is

$$C_2 V_{opp} = (I_{ref} - I) \tau = I \cdot t$$

Hence,  $I(\tau + t) = I_{ref} \tau$

$$f = \frac{1}{T} = \frac{1}{\tau + t} = \frac{I}{I_{ref} \cdot \tau} = \frac{I'}{I_{ref} \cdot \tau} \left( \frac{V_c}{R_{FT}} \right)$$

This means that the output frequency is controlled by the voltage applied to ② PIN and the resistance at ① PIN.

## {OUTLINE OF VCO III CIRCUIT OPERATION}

The output frequency of VCO III varies exponentially with respect to the input voltage at ② PIN, and linearly with respect to that at ⑮ PIN.

- In this circuit, the characteristics of VCO III are utilized to obtain the musical interval frequencies ( $C_2$  to  $C_6$ ) related by integral factors by applying exponentially changing voltage (250 mV to 4V) to ② PIN.
- The low frequency signal is applied to ⑮ PIN to modulate the output frequency for realizing the vibrato effect.

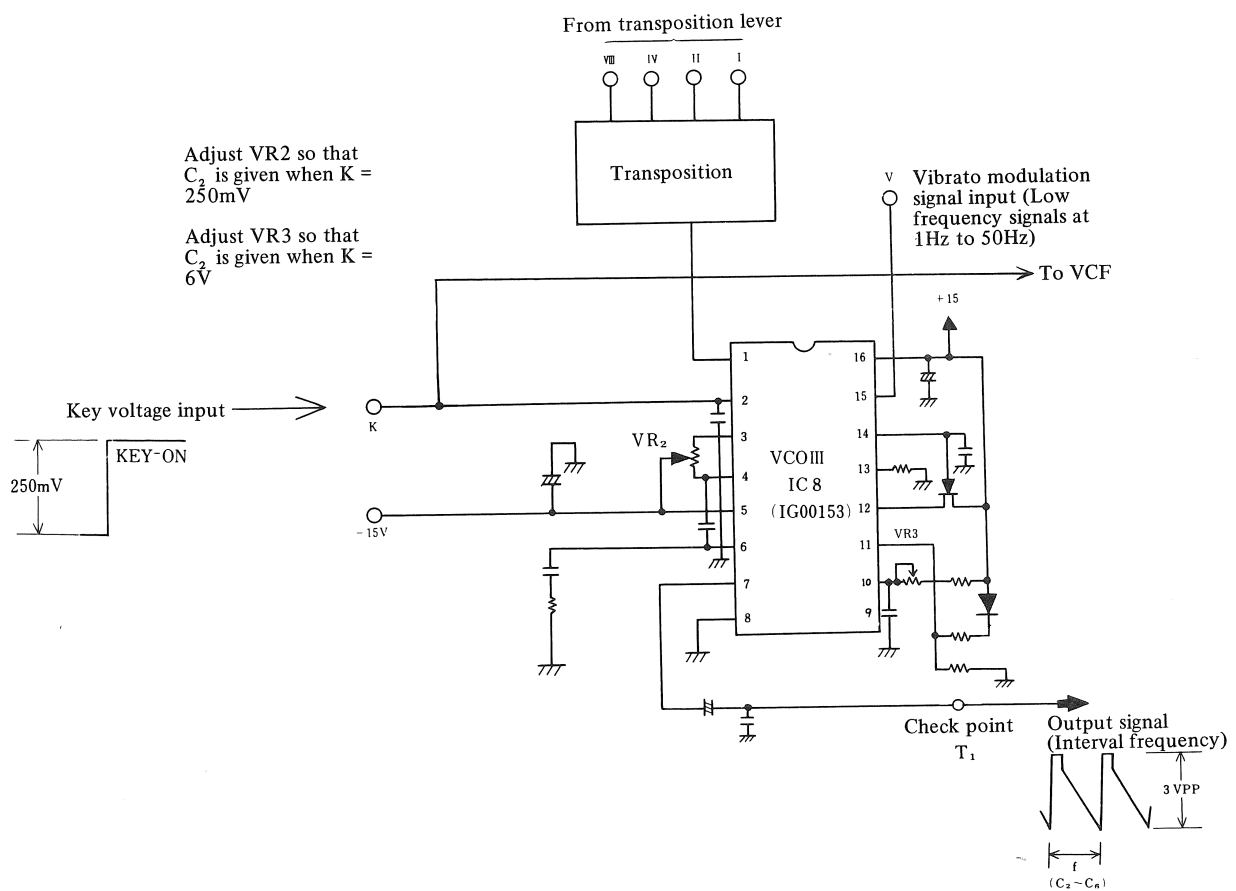

### • INPUT/OUTPUT CHARACTERISTICS

(TRANSPOSITION AT "NORMAL")

Input Voltage (KEY voltage)	Output Frequency	
	Frequency	Interval
250mV	130.8 Hz	$C_2$
500mV	261.6 Hz	$C_3$
1V	523.2 Hz	$C_4$
2V	1046 Hz	$C_5$
4V	2093 Hz	$C_6$

When the key voltage applied to ② PIN varies exponentially, for each octave the sawtooth wave output having musical interval frequency of octave relation appears at ⑦ PIN.

The higher the voltage to ② PIN, the higher becomes the interval frequency, and vice versa.

# [TRANSPPOSITION CIRCUIT]

In the VCO III circuit shown on page 27, if the bias resistor  $R_{FT}$  connected to ① terminal of IC, that is, the emitter of Tr1, is changed, the discharge time of  $C_2$  is varied. In this way, the frequency of the output signal is controlled by changing the ON-OFF time of the FET. If a few resistors of which resistance values hold the octave relationship are connected and selected by a switch, the octave transposition can be realized.

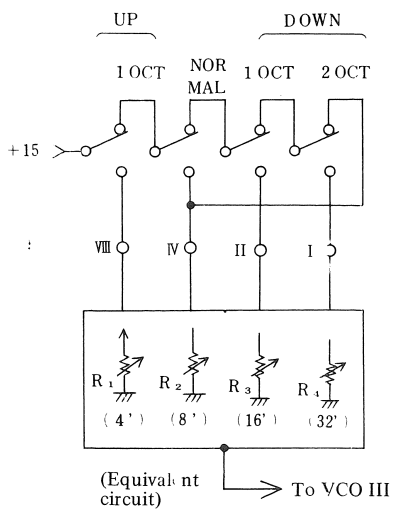
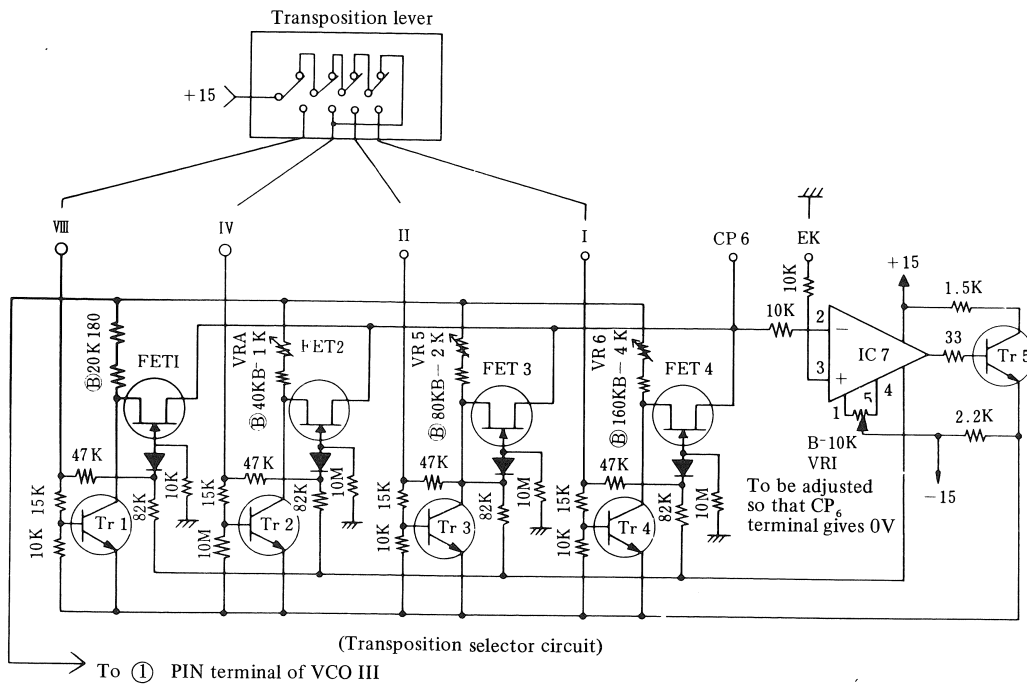

The transposition selector circuit can be represented by an equivalent circuit shown at the left with ① PIN of VCO III virtually grounded through resistors ( $R_1$  to  $R_4$ ) which determine octaves. This circuit prevents the click noise occurred due to turning of transposition lever and stabilizes the virtual grounding. When the octave switch 2 OCT. DOWN is turned ON, +15V applied to the terminal IV (Normal) is cut off, to set the terminal I (2 OCT. DOWN) to +15V and drive the FET gate and the TR4 base positively turning them ON. The negative voltage at the TR4 emitter is led to - input terminal of IC7 through the TR4 collector and FET. Since the NFB loop of IC7 is nearly shorted with gain reduced, the output of IC7 is at low positive voltage to turn TR5 ON. At the TR5 emitter, +15V and -15V cancel each other to results in nearly ground potential, which is fed to the TR4 collector. The IC7 works as a differential amplifier with + input terminal at ground potential, controlling the changes in the collector voltage of TR4 with TR5 to obtain a ground potential that is virtually always stable.

## [WAVE SHAPER CONVERTER CIRCUIT (WSC)]

- This circuit provides source wave shapes of different harmonic composition determining the tone color on the basis of sawtooth wave ( $\nearrow$ ) created by the VCO.
- The VSC produces 3 kinds of wave shapes: Sine ( $\sim$ ), sawtooth ( $\nearrow$ ) and square ( $\square$ ). Besides, the square wave can be converted to asymmetric one by changing the duty ratio.
- The noise created by the noise generator is also used as the sound source.

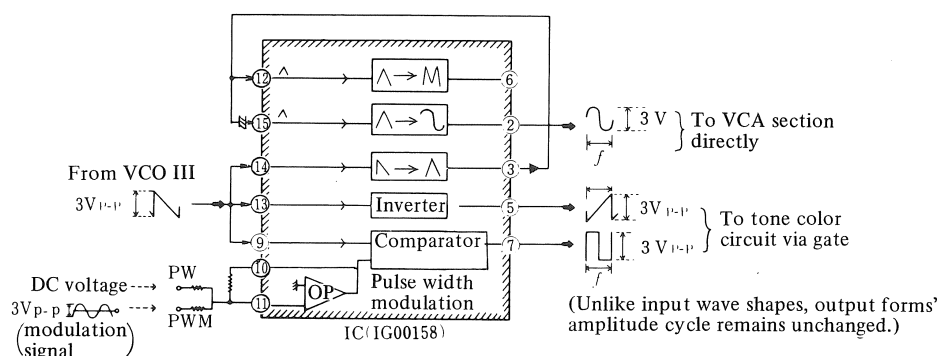

In the comparator having the pulse-width modulation function, the duty ratio of rectangular wave can be controlled by the voltage fed into PW and PWM terminals.

- DC voltage is applied to the PW terminal to set the duty ratio.

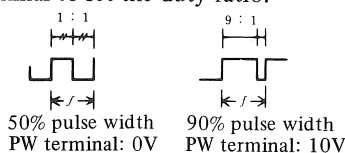

The PW terminal voltage is controlled for 0 ~ 10V with the PW lever.

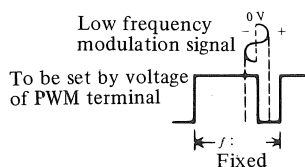

- To the PWM terminal, the low frequency modulation signal (sine wave) is applied in combination with the DC voltage applied to the PW terminal to change the control voltage of the comparator. The output pulse wave shape changes the duty ratio around that determined by the PW terminal voltage by the amount corresponding to the amplitude of, and at the rate corresponding to the frequency of the low frequency signal applied to the PWM terminal.



The maximum amplitude of the low frequency modulation signal is  $\pm 1.5V_{p-p}$ . In this case, the duty ratio varies by  $\pm 40\%$  around the duty ratio set by the PW lever. A duty ratio greater than 990% can not be realized because of saturation.

The amplitude and the frequency of low frequency modulation signal at the PWM terminal are controlled by the PWM lever and the SPEED lever, respectively. The recurrent frequency of output square waves is held constant. Since only the fall of pulse changes, the resultant sounds are like the concert of two signal sources.

- **Outputs of the wave shaper converter**

-  Sawtooth wave shape  
It has integral-numbered harmonics (1, 2, 3, ...) and is useful in producing string sounds like those of violins.
  -  50% pulse  
Square wavelshape  
It has odd-numbered harmonics (3, 5, 7 ...) and is useful in producing the clarinet-like sounds.





# VOLTAGE CONTROLLED FILTER

## BASIC CONSTRUCTION OF VOLTAGE CONTROLLED FILTER

The wave shape determined by the harmonic composition is one of the most important factors for defining the tone color. If the harmonic composition is controlled, desired tone color can be synthesized. This is realized by shifting the cut-off frequency of the tone filter through the control of voltage. If the time-dependent envelope voltage is applied as the control voltage, the tone color from the rise to the decay of sound can be controlled at will. The filter of which cut-off frequency is controlled by the voltage change is called the voltage controlled filter (VCF).

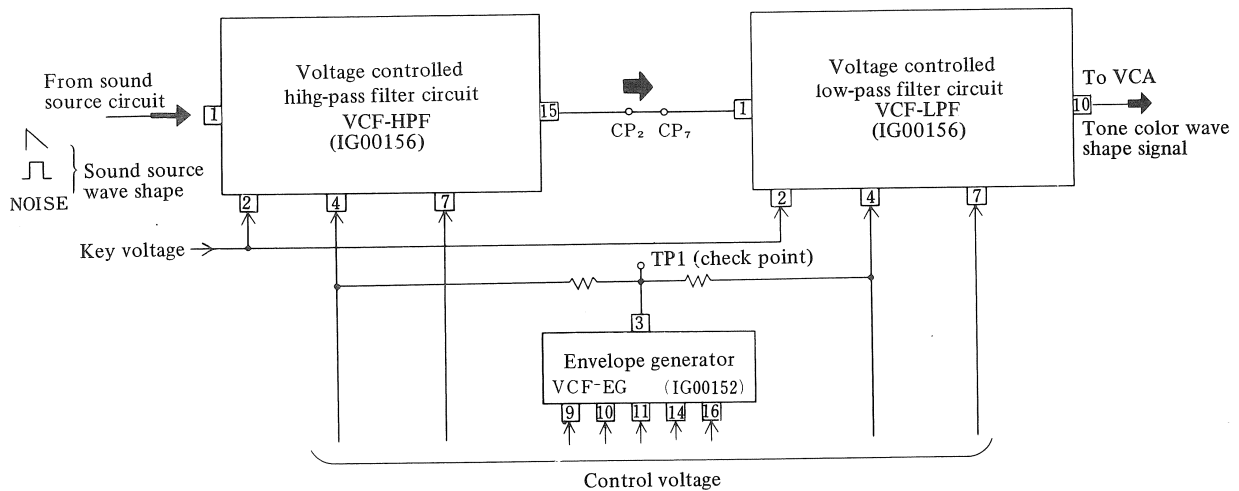

As shown in the above, there are two types of VCF: high pass (HPF) and low pass (LPF), both of them can provide not only the time-dependent envelope voltage but also the stable DC voltage, as manually selected by a lever on the panel.

## OPERATIONAL PRINCIPLE OF LSI (IG00156)

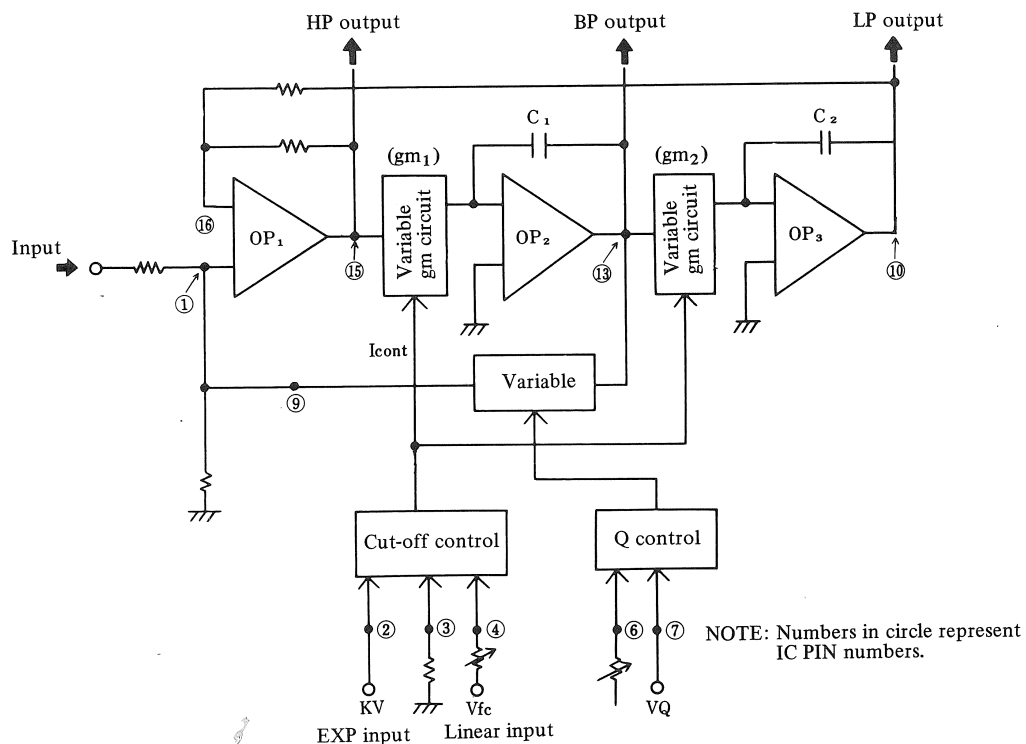

This circuit is a state variable filter, giving high-pass and low-pass outputs at 15 PIN and 10 PIN, respectively, at the same time. The conductance values of  $gm_1$  and  $gm_2$  are controlled by the voltage  $K_V$  and  $V_{fc}$ , and the cut-off frequency of filter ( $f_c$ ) is determined by time constants,  $gm_1 \cdot C_1$  and  $gm_2 \cdot C_2$ . That is, the filter characteristics can be controlled by the input voltage.

$$f_c = 125 K_V \cdot 2^{V_{fc}}$$

where  $K_V$ : key voltage  
 $V_{fc}$ : cut-off frequency control voltage

The frequency characteristics of this filter with 2-staged integrating circuit is 12 dB/OCT filter in both high-pass and low-pass filters.

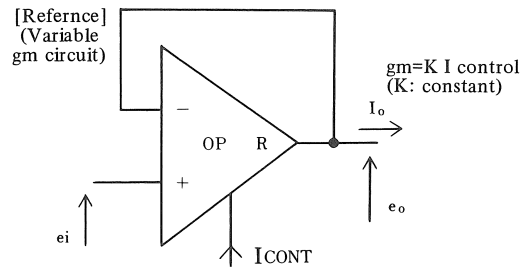
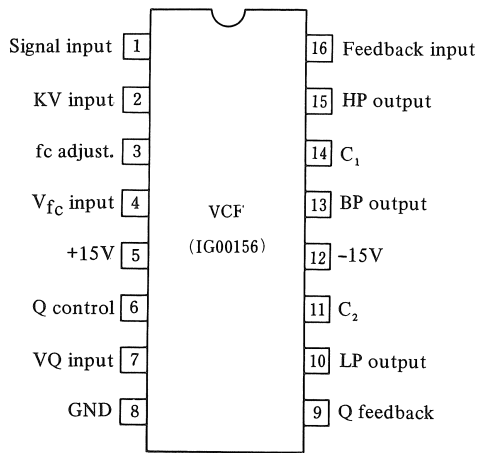

The variable gm circuit is a kind of gate circuit with the conductance controlled by the control current ( $I_{cont}$ ).

## ● OUTLINE OF VCF CIRCUIT OPERATION

### Operation of Filter Circuit

As stated in the above, the tone color is determined by the harmonic composition of the signal wave shape. The analysis of tone color wave shape reveals that it consists of fundamentals which determine the musical interval of signal and harmonic components which have integral multiples of fundamental frequency. Accordingly, the tone color can be varied by changing the harmonic composition by use of the filter circuit.

The filter circuit is classified into two types: high pass (HPF) and low pass (LPF) filter, the former passes components having a frequency above a certain value, and the latter just the opposite. The boundary frequency is called the cut-off frequency, and the harmonic composition of a tone can be altered by changing the cut-off frequency. The cut-off frequency of the VCF circuit is controlled by the voltage: the higher the voltage, the higher becomes the cut-off frequency.

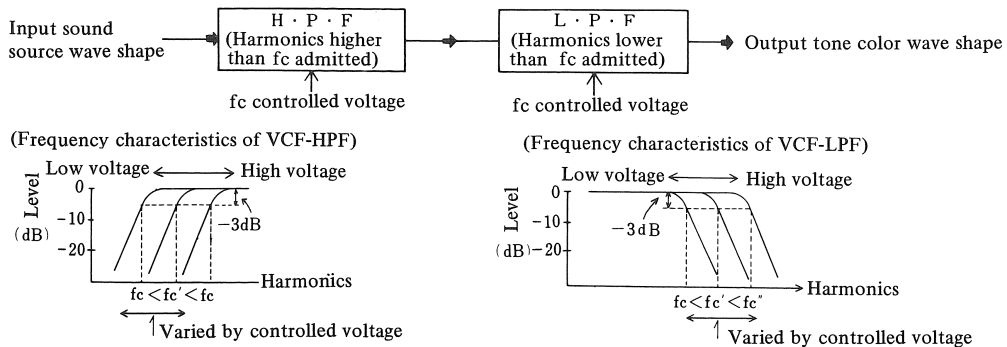

In case of the high pass filter, the lower order harmonics below the cut-off frequency which is determined by the voltage are more markedly attenuated, while in case of the low pass filter, the higher order harmonics above the cut-off frequency are attenuated. In this way, the tone color can be varied by controlling the cut-off frequency with time-dependent voltage. Besides, the stable tone control is also available by changing the DC voltage manually with a lever on the panel.

The control voltage is varied by use of HPF and LPF levers.

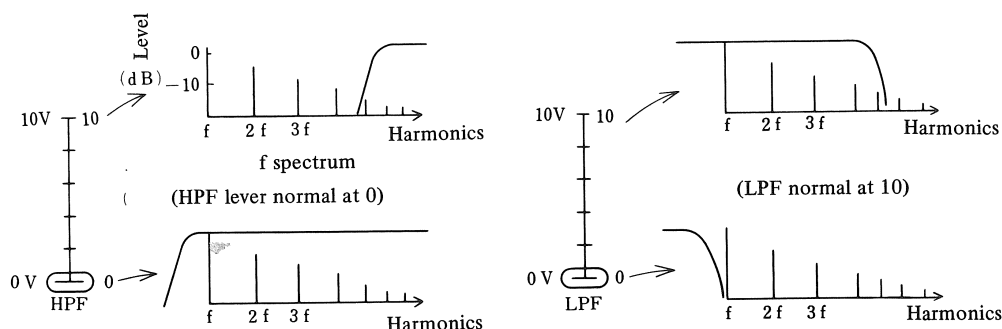

### • HARMONIC COMPOSITION AND TONE COLOR WAVE SHAPE

When the tone includes more high-order harmonic components of fundamental, the wave shape becomes sharper, and the tone hard. On the other hand, if the tone contains less high-order harmonics, the wave shape become rounder and tone soft. The contents of high-order harmonics are determined by the cut-off frequency of the filter. The changes of tone color as controlled by LPF are illustrated at the right.

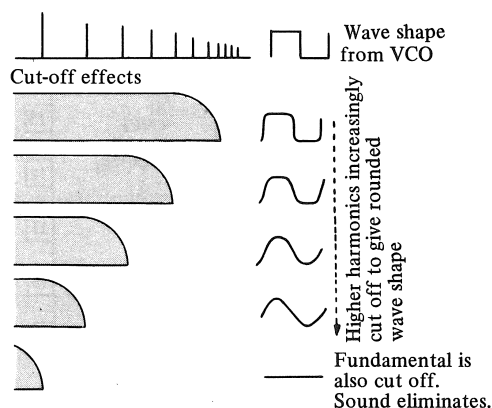

### • KEYBOARD FOLLOWER

The keyboard follower provides key voltage depending upon the depressed key in combination with the control voltage for the cut-off frequency of VCF, as the follower voltage. This eliminates the following disadvantages, and keeps identical tone color from the lows to the highs of the keyboard.

For instance, if the cut-off frequency of the filter is fixed so as to cut frequency component above 1 kHz, the harmonics of  $A_1$  (110 Hz) contain up to the fourth harmonic (880 Hz), while those of  $A_3$  (440 Hz) contain only the second harmonic (880 Hz). Accordingly, these two tones have different colors. Tones higher than  $A_5$  (1760 Hz) cannot be produced.

When the keyboard is used over a wide range, therefore, the tone color varies depending upon the key position, and the highs may be markedly attenuated or cannot be produced at all. For this reason, the key board follower circuit is provided so as to correct the cut-off frequency in accordance with the key position.

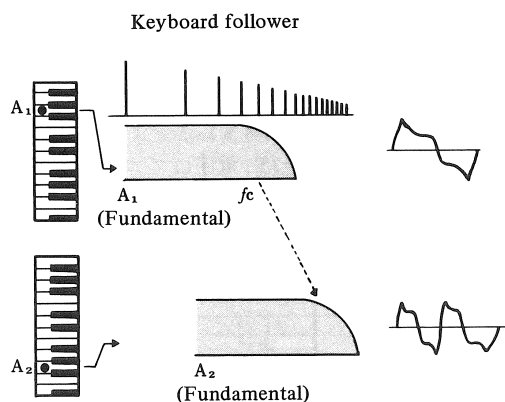

- Cut-off frequency is automatically shifted to keep harmonic composition unchanged

In the VCF circuit, the key voltage fed into VCO III is branched to provide the control voltage for correction to the key position. The control voltage is fed into the VCF so as to provide the tone of same harmonic composition whichever key may be depressed.

That is, the resultant tone color is not affected by the key position.

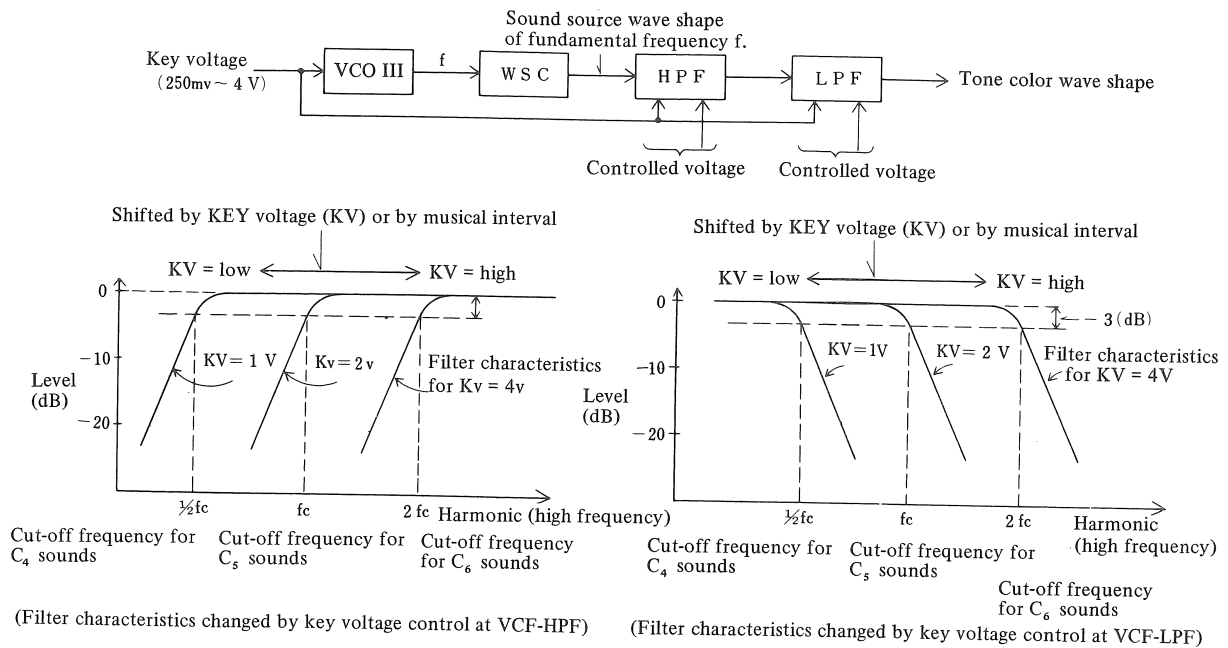

When the control key voltage is changed exponentially, the cut-off frequency is shifted in the octave relation. This characteristics of VCF assures uniform harmonic composition over various key positions.

### • VCF CIRCUIT AND VCF CONTROL CIRCUIT

In the mechanical instruments, the tone color changes continuously from the beginning of sound to its die away, as mentioned. Such a time-dependent change in tone color may be obtained by feeding into the VCF a voltage envelope which continuously changes with time simulating the tone color change.

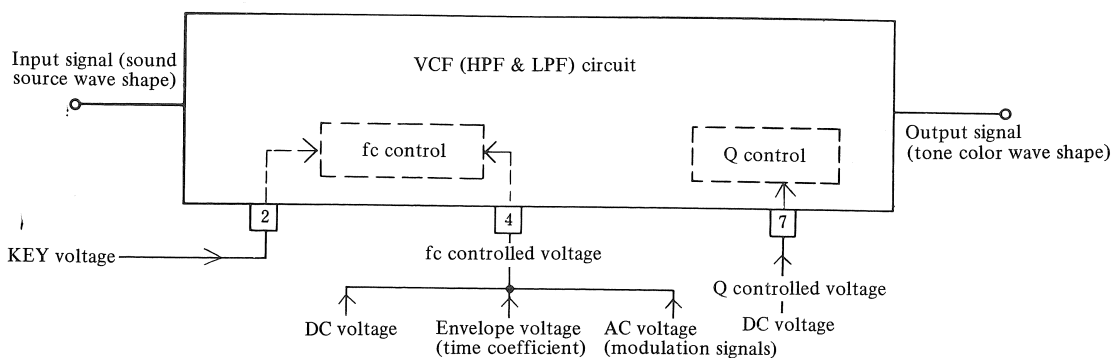

● **fc CONTROL VOLTAGE**

**a. Tone Color Change by Envelope Voltage**

The actual voltage envelope is as shown below. It covers the time from the rise to the die-away of the signal.

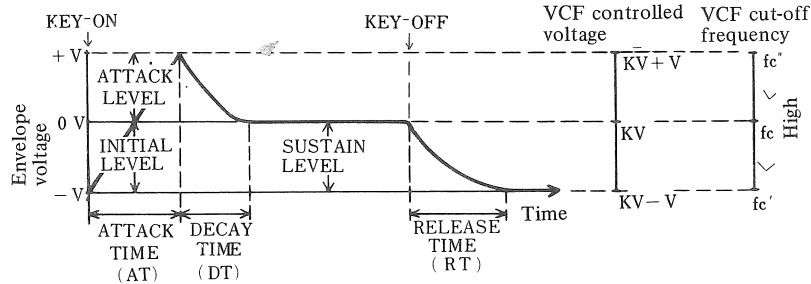

**Initial level:** This level determines how low the cut-off frequency of the filter should be compared with normal cut-off frequency, to start the sounds the moment the key is pressed. The lower this voltage, the better start of sounds is ensured with a minimum of harmonics.

**Attack Level:** During the process from the moment the key is depressed until actual sounds are produced, sounds sometimes include harmonics that are higher than the normal harmonics structure. Therefore, in contrast to the cut-off frequency, points leading to the production of sounds including those at peak cut-off frequency – harmonics of the highest order – are defined as the Attack Level. And the higher this voltage, the higher the frequency will rise.

**Decay Time:** Is defined as the time taken by the cut-off frequency falling from the peak level to the proper level for the depressed key.

**Sustain Level:** Maintains the cut-off frequency at a steady level corresponding to the depressed key as long as the key is held depressed.

**Release Time:** Is defined as the time for the cut-off frequency declining from the sustain level to the initial level.

The changes in the cut-off frequency and the wave shapes in the course of time corresponding to the voltage envelope are illustrated right.

The envelope voltage is produced, by the envelope generator to be described later. (Refer to p. 45 EG)

**b. Tone Color Change by Low Frequency Modulation Signal**

When the low frequency signal from the sub-oscillator is applied as the control voltage for the cut-off frequency, the latter changes at the period of low frequency, varying the tone color continuously and periodically. This allows simulation of the vibrato-like effect as in case of a wind instrument.

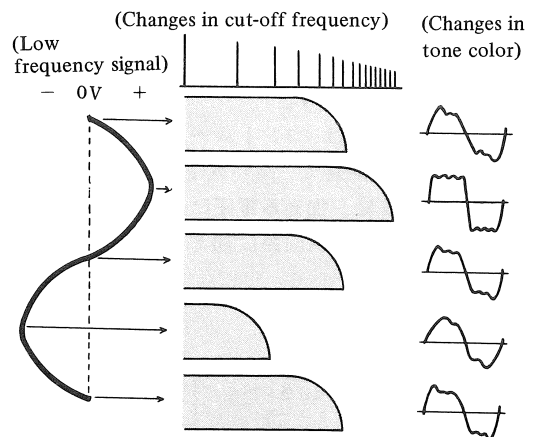
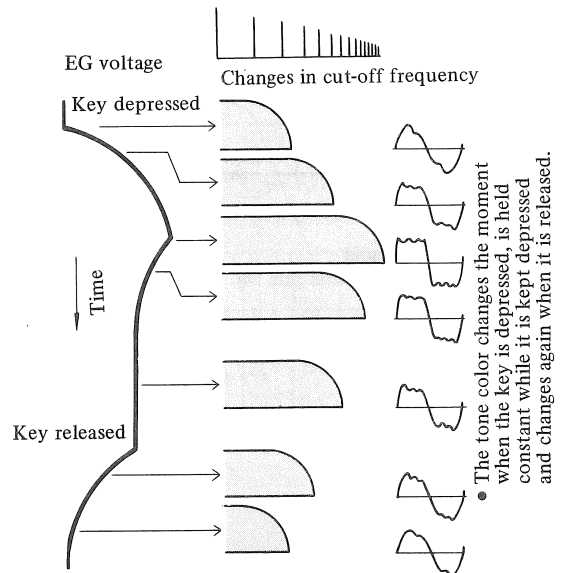

- **RESONANCE (Q)**

The resonance is obtained by drastically emphasizing the band of frequencies around the cut-off frequency. This is extremely important in synthesizing sounds, since almost all the musical instruments have their own resonances which critically determine the characteristic tonal color. The resonance can be controlled by the voltage at the Q-terminal of VCF IC.

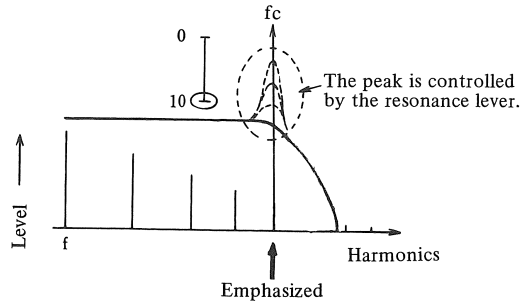

- **CONSTRUCTION OF TONE COLOR CIRCUIT**

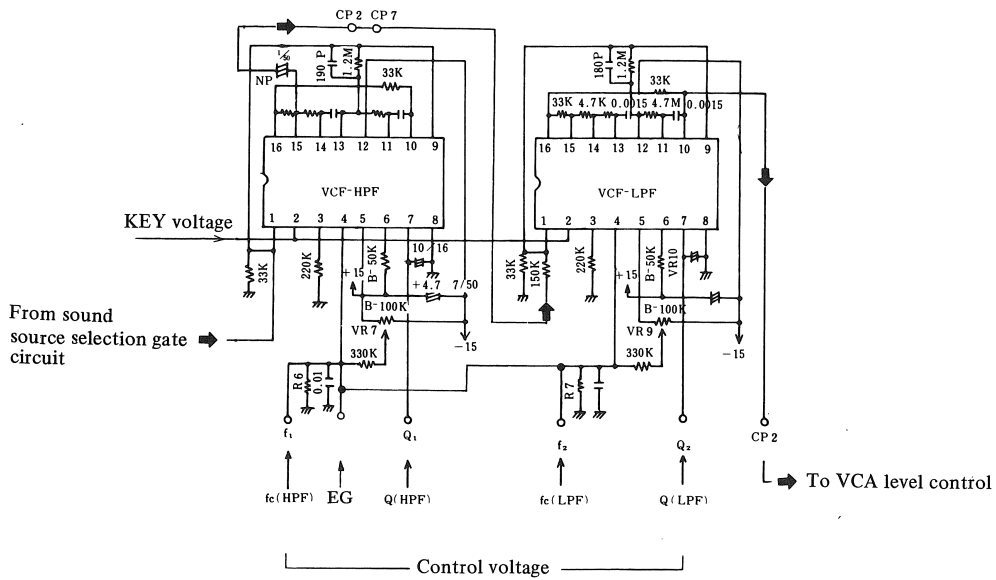

# ● VOLTAGE CONTROLLED AMPLIFIER CIRCUIT

## ● BASIC CONSTRUCTION OF VOLTAGE CONTROLLED AMPLIFIER CIRCUIT

An amplifier of which gain can be controlled by the applied voltage is called voltage controlled amplifier (VCA). The VCA consists of variable conductance (gm) circuit of which conductance is controlled by the voltage-to-current conversion of externally applied control voltage. This allows modification of the amplitude of sound signal passing through the VCA with the control voltage.

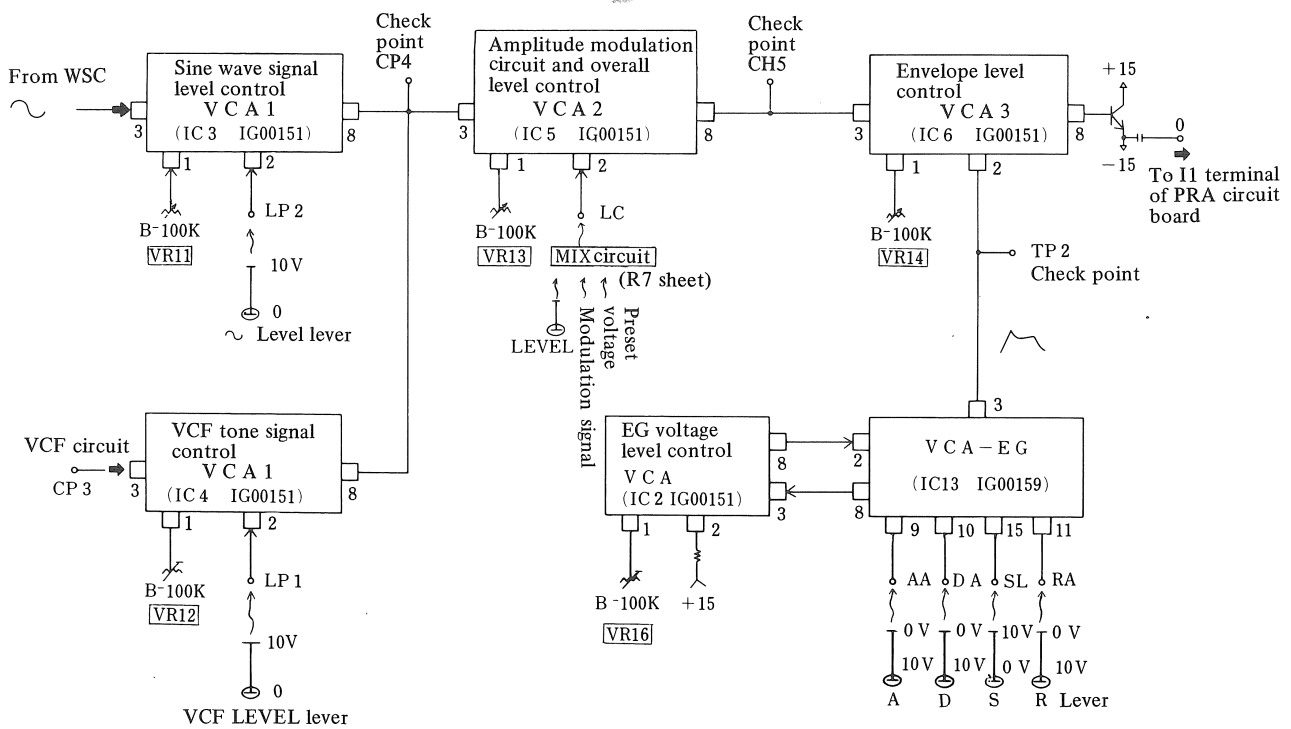
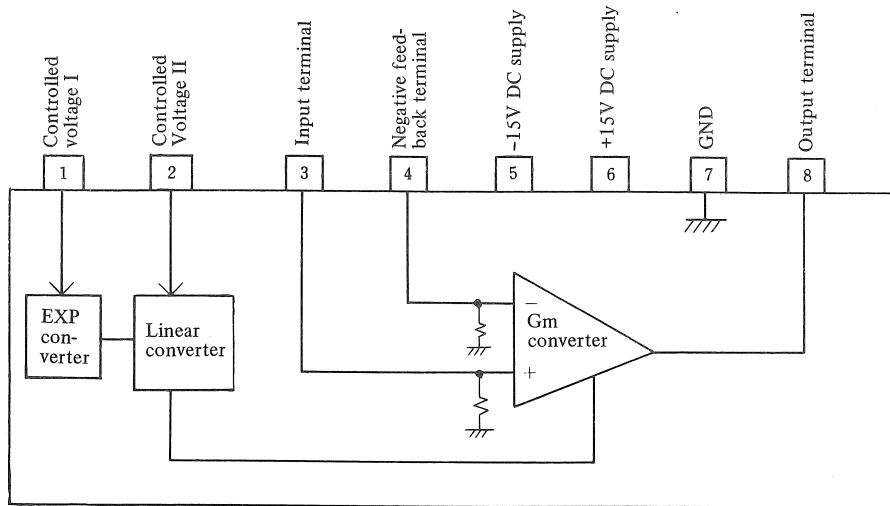

Fig. 6-1 Basic Construction of VCA Circuit

The VCA consists of three circuits: VCA 1 which is statically controlled by the manual lever on the panel, VCA 2 which is controlled by the sub-oscillator modulation (AM) signal and the control voltage of preset tone, and VCA 3 which is controlled by envelope voltage.



• OPERATIONAL PRINCIPLE OF LSI (1G00151)



(1G00151)

As described in the section of VCF, this IC is used as the so-called variable gm circuit. The conductance gm of operational amplifier can be varied by  $I_{cont}$ .

$$G_m = K \cdot I_{cont} \quad K: \text{constant}$$

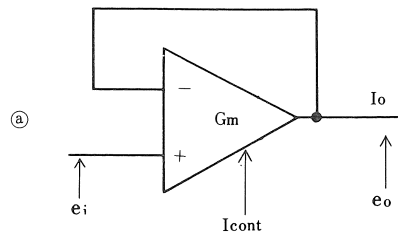

The greater the control current or the control voltage, the greater the gm, and hence the signal level. The output level changes exponentially to the voltage given to PIN 1 and also changes proportionally with the voltage given to PIN 2.

• OUTLINE OF VCA CIRCUIT OPERATION

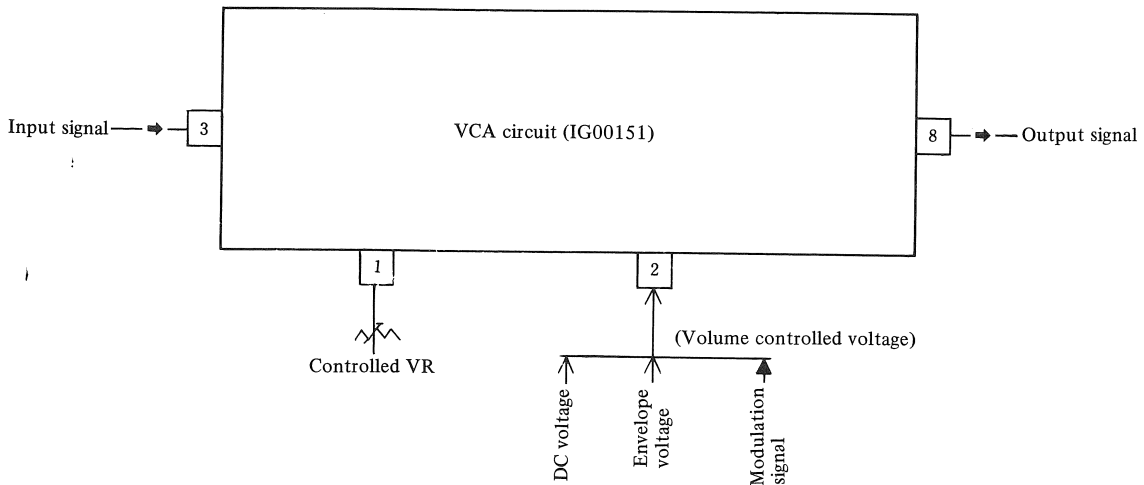

- The IC (IG00151), is adjusted by the semi-variable resistor connected to PIN 1 so that the output voltage is 0 when the voltage at PIN 2 is 0V, and the maximum output is obtained when the latter is 10V. Three kinds of control voltage are available.

**DC voltage**

Manually setting the control level on the panel allows to adjust the control voltage so as to set the amplitude ratio statically with respect to time, like a volume control.

**Low frequency AC voltage**

The VCA is used as an AM modulator, applying the modulation signal to obtain tremolo, repeat and other volume-related effects.

**Envelope voltage**

When synthesizing a tone color or preparing a preset tone, the time-dependent parameters of tone to be simulated, such as rising rate, peak level, decay time, sustain level, sustain time, etc. may be substituted with a voltage envelope. This can be manually controlled by use of a lever on the panel. (Refer to Fig. 6-1).

- Signal volume varied by modulation signal

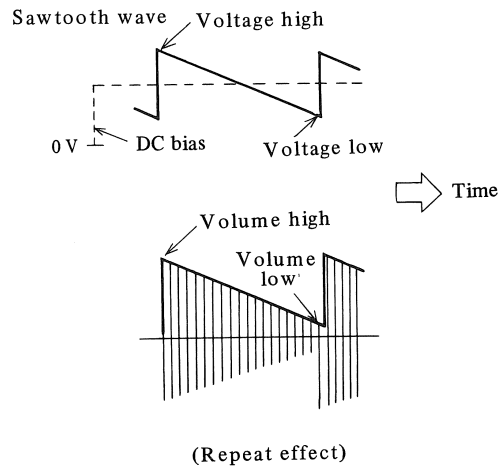
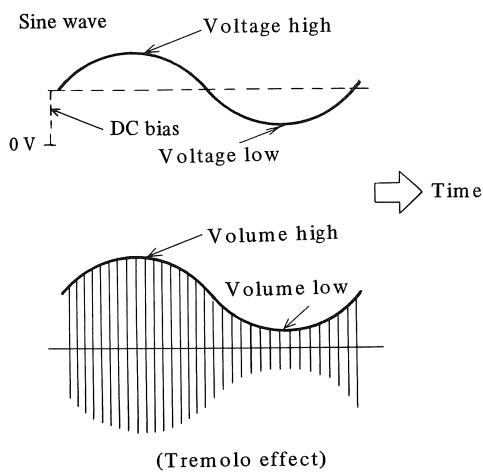

○ For envelope voltage, refer to section on VCA-EG.

# ENVELOPE GENERATOR

## • BASIC CONSTRUCTION OF ENVELOPE GENERATOR

A time-dependent DC voltage generator. In this circuit, the sound parameters such as rising rate following key-ON, peak level, decaying rate, sustain level for steady key-ON, time from release to die-away are substituted by voltage level, time course of voltage change or slope, which are combined to form a voltage envelope. There are two envelope generators, for VCF and for VCA.

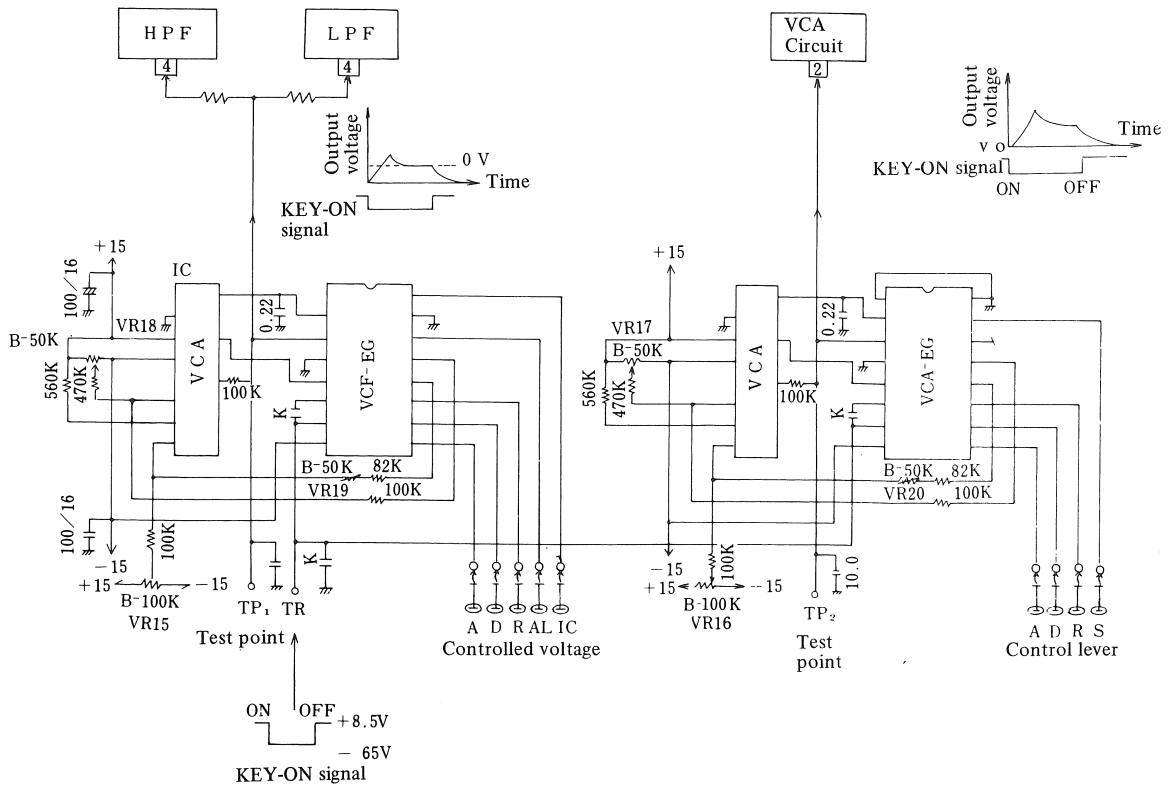

The output of VCF-EG circuit is used as the control voltage for VCF cut-off frequency, and that of VCA-EG circuit as the volume control voltage for VCA circuit.

● OPERATIONAL PRINCIPLE OF LSI (G00159)

In principle, the envelope generator consists of variable resistor circuit. (variable current circuit with equivalent VCA), variable integrating circuit consisting of capacitors and sequence circuit. The segments of envelope defined by attack time, decay time and release time which are set by the variable integrating circuit are linked up by switching with the sequence circuit to make a complete envelope.

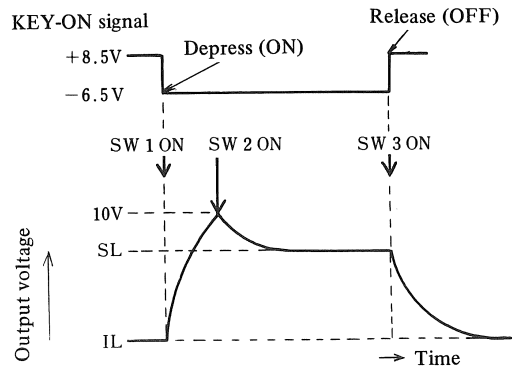
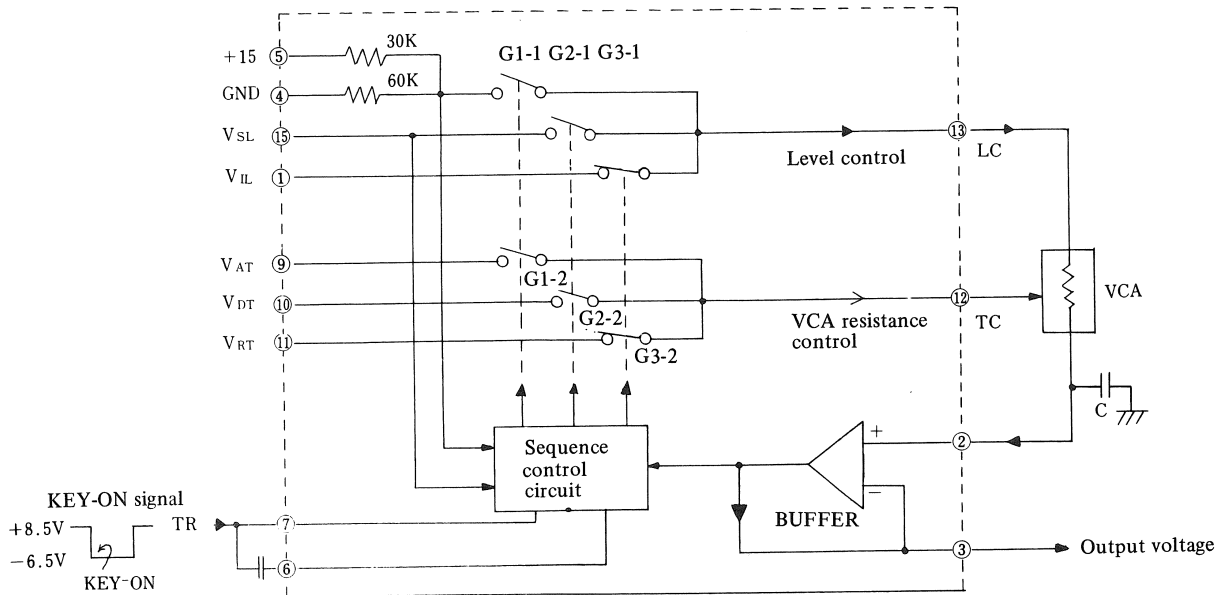

**Principle of Operation**

The diagram in the above indicates the principle of operation.

- 1) When no key is depressed, Gate 3 is ON, and  $V_{IL}$  (initial level voltage) is applied to the VCA through Gate 3 and LC. Besides,  $V_{RT}$  (release time voltage) is also fed into TC (time control) terminal through Gate 3-2. Under this condition, gm of VCA is maximum with very low impedance and the capacitor is discharged through VCA down to  $V_{IL}$ . For this reason, the output of buffer amplifier is equal to  $V_{IL}$  and fed into the sequence control circuit, to compare the input data (DC potential) to Tr terminal and keep Gate 3 ON.
- 2) When a key is depressed, the key-ON data is fed into Tr terminal to open Gate 1-1. This allows about 10V signal, which is provided by dividing +15V with 30 k $\Omega$  and 60 k $\Omega$  resistors, to be applied to VCA through Gate 1-1. On the other hand, the DC voltage set on the panel by A lever for attack time is applied to  $V_{AT}$  terminal through Gate 1-2 and TC terminal. These time control voltages control the variable resistor circuit made up by VCA so as to vary the slope to the peak level (attack level), 10V. When the capacitor voltage attains the attack level

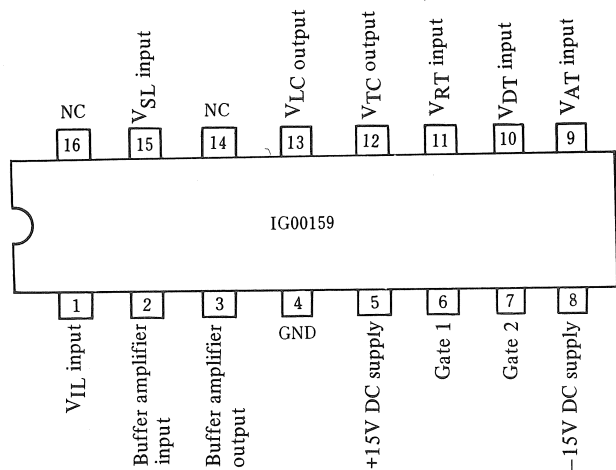

in the set time,  $V_A = V_B$  (10V), which is detected by the sequence control circuit, turn Gate 1 off and Gate 2 on.

- 3) When Gate 2 is turned on,  $V_{SL}$  (sustain level voltage) set by S lever on the panel is applied to the VCA through  $V_{SL}$ , Gate 2-1 and LC. At the same time, the voltage set by D (decay time) lever changes the equivalent resistance of VCA, and the decay time from the attack level (10V) to the sustain level is determined by the time constant for this resistance and the capacitor. When the buffer output  $V_B$  becomes equal to the sustain level voltage at  $V_{SL}$ , this state is held until the key is released.
- 4) When the key is released, the key-OFF data is fed into Tr terminal and the sequence control circuit to turn Gate 2 off and Gate 3 on. Then  $V_{SL}$  is discharged down to  $V_{IL}$  in a time determined by  $V_{RT}$ .

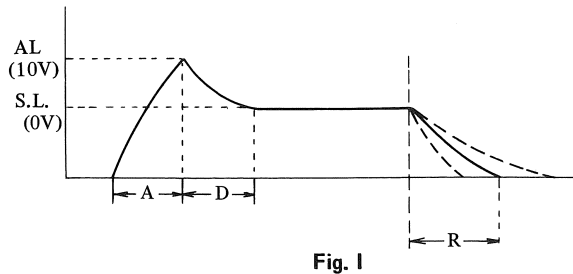
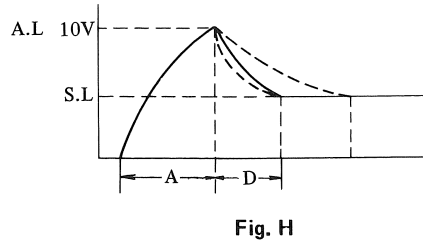
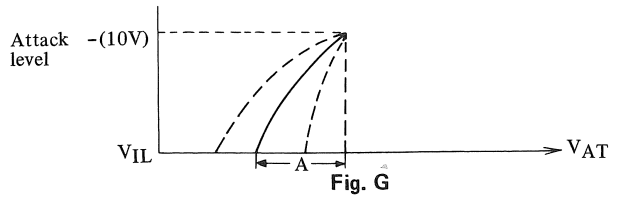

● OUTLINE OF VCA-EG OPERATION

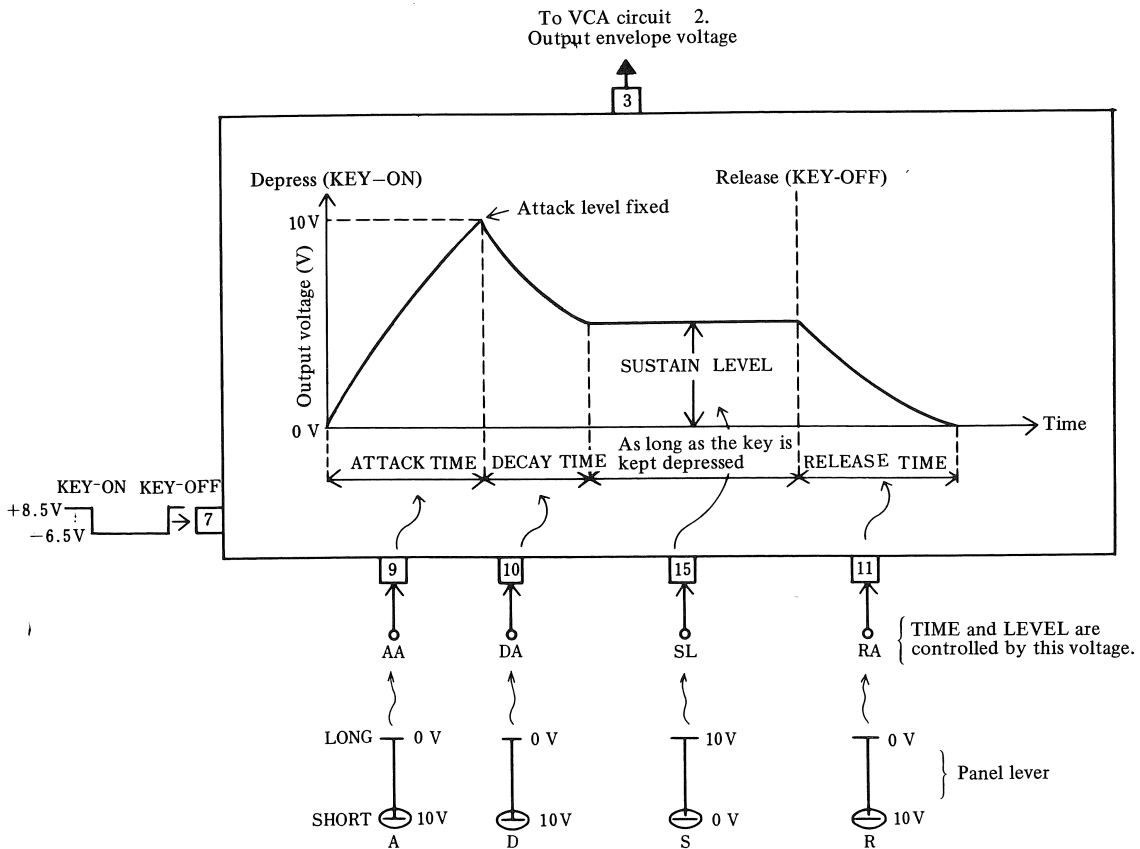

The tone of a musical instrument is not at a constant level from the start to the die-away. At the moment a key is depressed, the sound becomes gradually louder until a certain peak is attained. The time up to this is called attack time. Then, the loudness gradually decays to a steady level (sustain level). The time up to this is called decay time. It is possible that the attack level is equal to the sustain level. While the key is kept depressed, the sustain level is maintained, but as the key is released, the tone level declines gradually to ultimately die away. The time for this is called release time.

The time for this is called release time.

The envelope voltage controls the VCA circuit so as to change the time course of tone level as described in the above. In this circuit, the peak level (attack level) is fixed as illustrated in the above, and the other parameters A, D, S and R can be controlled as desired.

(Example) S(sustain level)  
lever set at high

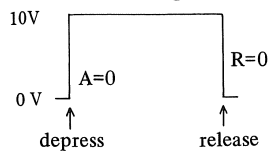

(Example) D(decay time)  
lever set at LONG

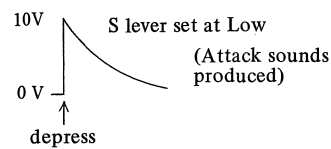

### ● OUTLINE OF VCF-EG OPERATION

As in case of VCA envelope generator, when the envelope as illustrated below is fed into the VCF circuit, the cut-off frequency of filter is controlled from the beginning to the die-away of sound to provide variation tone color and quality.

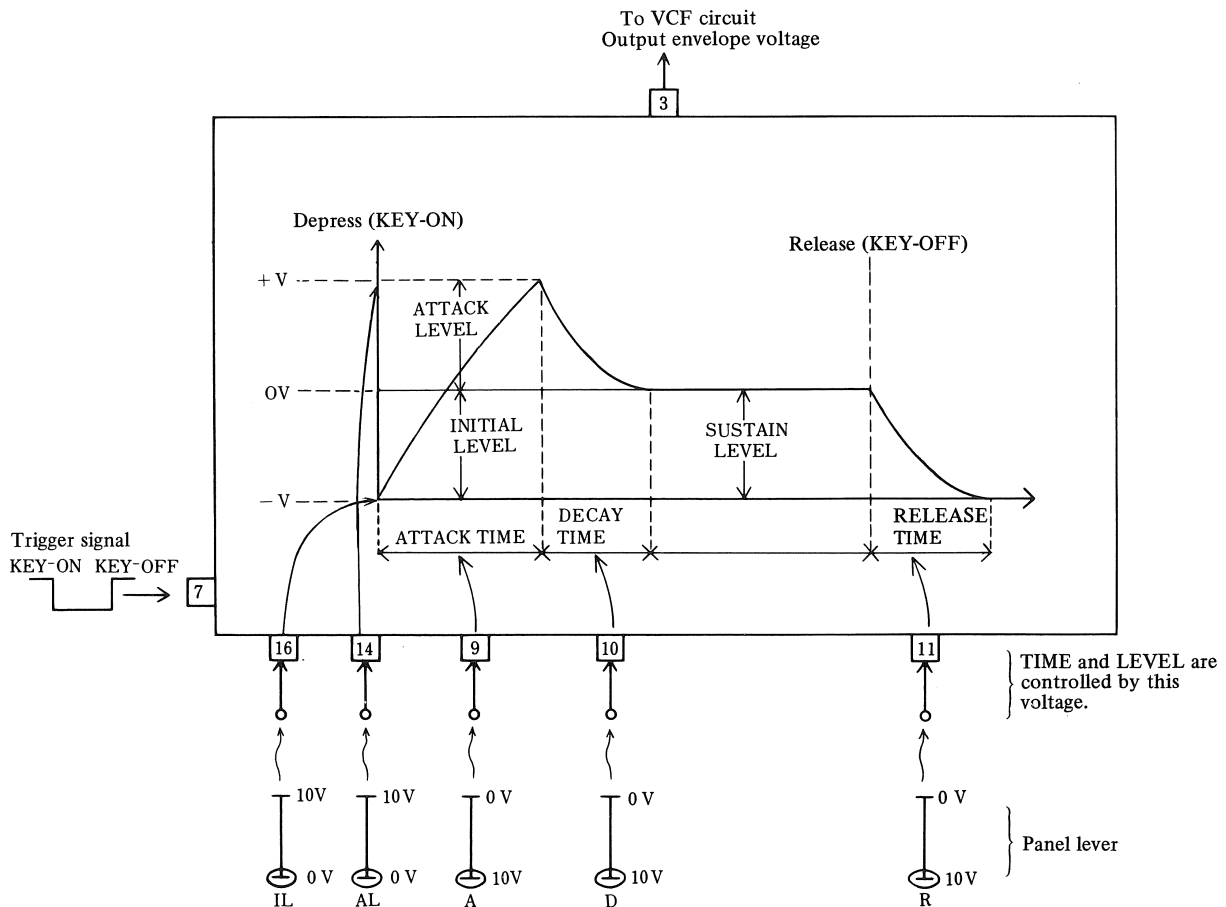

The principle of IC operation is nearly identical to that of VCA envelope generator except for the fact that the sustain level is set at 0V so that the tone color does not change while the key is kept depressed.

# EXPRESSION CIRCUIT

## ● EXPRESSION CIRCUIT

The expression pedal control circuit consists, as shown below, of expression pedal circuit, voltage-current (V-I) converter including an operational amplifier and photo-coupler including light-emitting diode (LED) to change light output in accordance with the current value and cadmium sulfide (CdS) photo conductor.

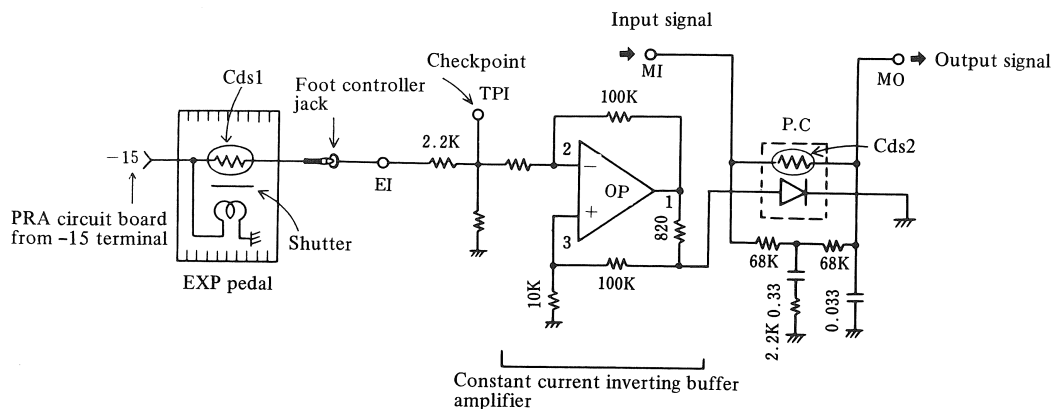

### [Outline of operation]

#### V-I Converter and Photo Coupler

The photo coupler contains a LED, and its gain is controlled by the current flowing through the LED. The voltage proportional to the degree of treading in the expression pedal must be converted to the current. The output current ( $I_o$ ) of V-I converter which is based on the inverting operational amplifier is given by the following equation:

$$I_o = \frac{R_f}{R_s} \cdot \frac{V_s}{R_3}$$

where  $V_s$ : input voltage from the expression circuit,

$$R_f = R_s = 100 \text{ k}\Omega \text{ and } R_3 = 820\Omega$$

$$\text{Hence, } I_o = \frac{1}{820} V_s$$

Thus, the output current of V-I converter is proportional to the voltage controlled by the expression pedal. The output current controls the light output of the LED, which changes the conductance of the CdS conductor in the photo coupler to control the tone volume.

## ● EXP Pedal and Foot-Controller Jack

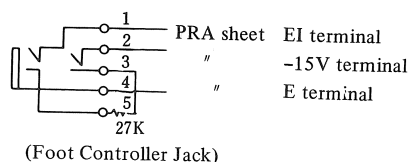
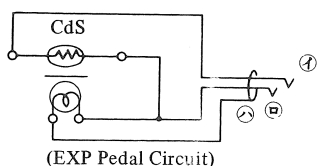

- When the expression pedal is not connected, terminals 2 and 3, and terminals 5 and 1 are in contact, respectively, and -15V is applied to the EI terminal through the 27 kΩ resistor. That is, if the expression pedal is not connected, the maximum volume is output.

- 
- When the expression pedal is connected, terminals 1, 2, 4 are connected to terminals A, B, C, respectively to supply  $-15V$  to the lamp, LED and the control voltage is output to the EI terminal through the CdS conductor.

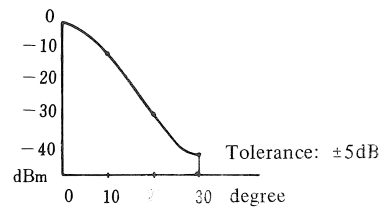



# OUTPUT AMPLIFIER AND HEADPHONE AMPLIFIER

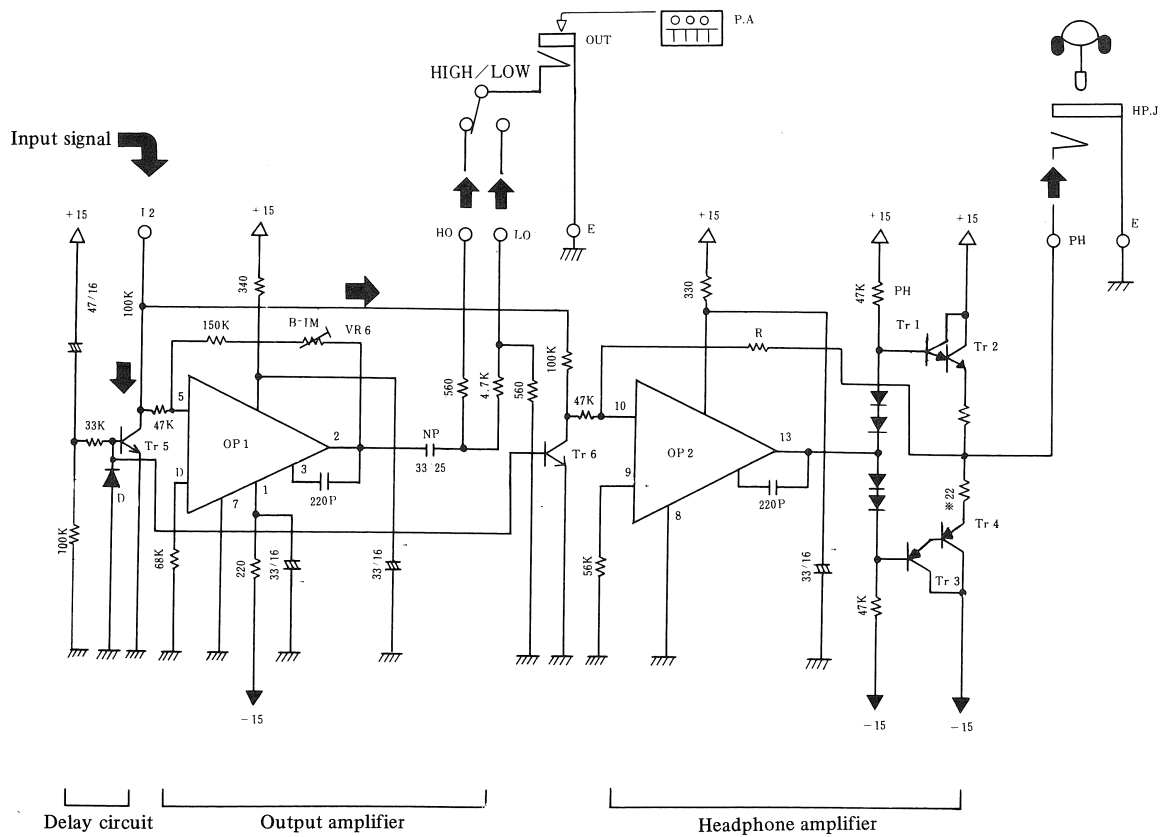

- Delay Circuit**  
 Transistors 5 and 6 turn conductive for about 5 seconds after the moment when the POWER switch is turned ON to lead the noise and unstable sound signal in the transient state to the ground. The delay time is determined by the  $47 \mu\text{F}/16\text{V}$  capacitor and  $100 \text{ k}\Omega$  resistor.
- Output Level Adjustment**  
 The maximum output level should be adjusted by VR6 to  $0 \pm 1 \text{ dBm p-p}$  at the HO terminal and  $-18 \pm 3 \text{ dBm p-p}$  at the LO terminal.
- Headphone Amplifier**  
 When a headphone ( $8 \Omega$  load) is connected, this circuit provides the maximum PH output level  $-6 \pm 2 \text{ dBm p-p}$ .

# MODULATOR CIRCUIT

## 1. PWM OSCILLATOR CIRCUIT

This circuit produces the low frequency modulation signal for changing the pulse width, that is, the duty ratio of square waves, one of sound source waves output by the source oscillator. Thus, the pulse width modulation (PWM) is obtained by this low frequency modulation signal.

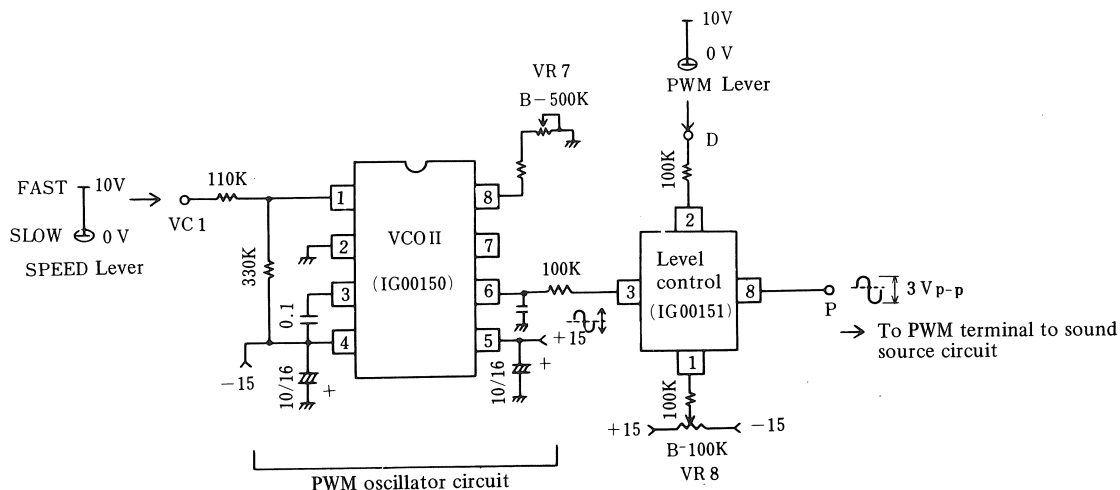

VC1 terminal voltage	VCO II oscillation
0 V	0.2Hz
5 V	6.7Hz
10V	222 Hz

The PWM oscillator is a voltage controlled oscillator (VCO II) like the sound source generator (VCO III). At PIN 6, the wave signal is output, with the frequency being controlled by DC voltage applied to VC1 terminal (PIN 1) and determined by the speed lever on the panel. The relationship of control voltage to oscillation frequency is controlled by VR7 as illustrated at the left. The amplitude of the output signal is 3Vp-p.

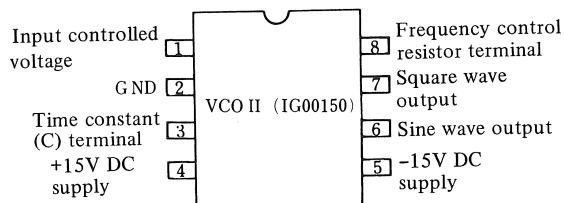

The principle of operation is same as that of sound source generator (VCO III). The VCO II contains in the IC and exponential converter which changes the linear speed control voltage into exponential voltage, and a wave shape converter which changes the sawtooth wave into the sine wave. In the VCO II, the sine wave is used as the modulation signal in place of sawtooth wave. The oscillation frequency varies exponentially with respect to the input voltage with a little adjustment as illustrated at the left.

### • Modulation Signal Level Control Circuit

The amplitude of modulation signal for PWM is set by the level control circuit based on the VCA, which is controlled by DC voltage set by PWM lever on the panel. Speaking more specifically, 0 to 10 V DC is applied to D terminal to control the amplitude of modulation signal. The gain of VCA is adjusted by VR8 so that the amplitude ratio is 1:1 (that is, the input level is equal to the output level) when 10V is applied. The modulation signal with the level controlled as described in the above is fed into the pulse width modulator in the WSC IC through the PWF terminal of M circuit board.

## 2. RING MODULATOR

This circuit ring-modulates the input signal by use of low frequency modulation signal and takes out the sum and difference of frequencies for two signals, to make beating.

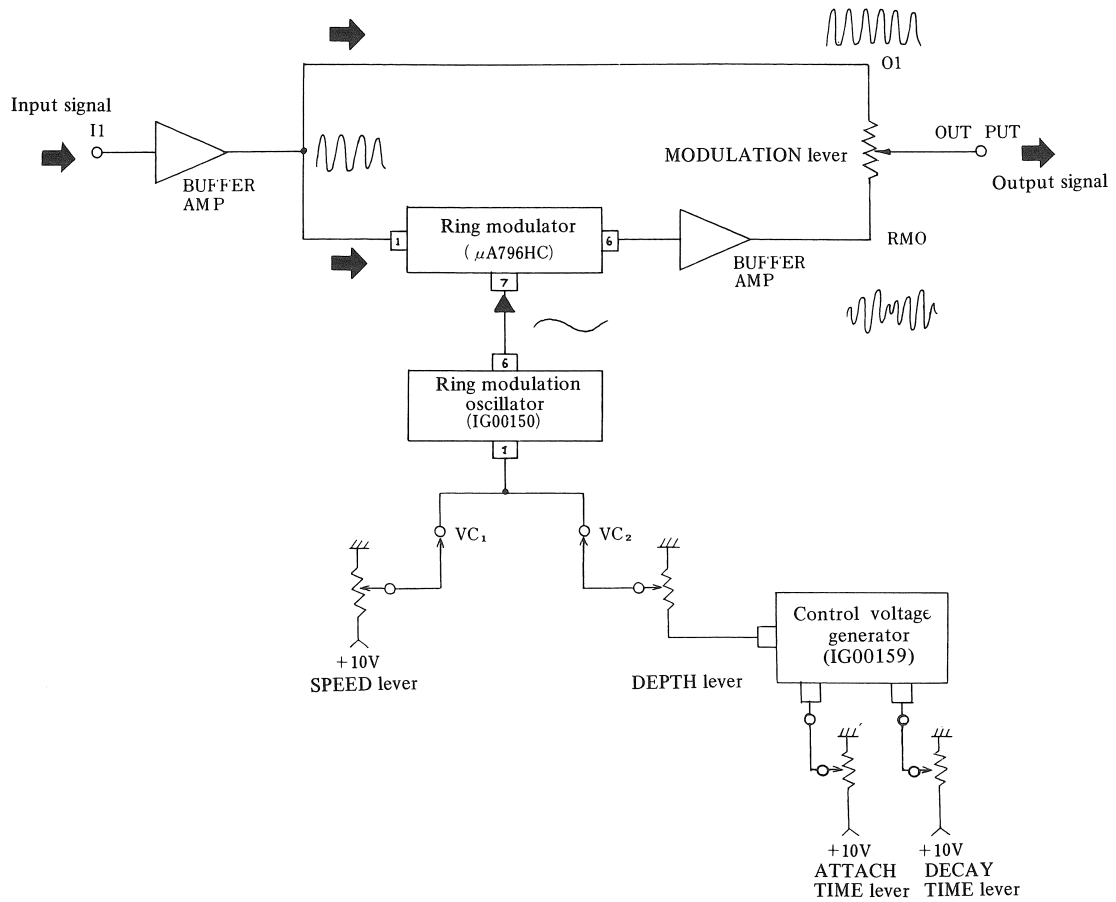

The ring modulation is a sort of amplitude modulation, but it is distinguished from the latter on the basis of following points. For instance, if the  $A_3$  key (440 Hz) is depressed and the ring modulation is made with 10 Hz modulation signal (signal at 7 PIN of ring modulator), the output signal includes the sum and difference of two signals (450 Hz and 430 Hz) and does not contain 440 Hz input signal, in contrast from the amplitude modulation of controlling the VCA with the sub-oscillator. That is, though only a key is depressed, two signals of different frequencies from that depressed key are created. The frequency spectra and the wave shape of these signals are as illustrated below.

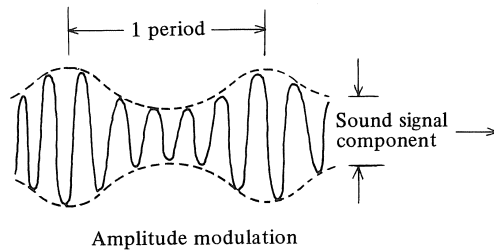
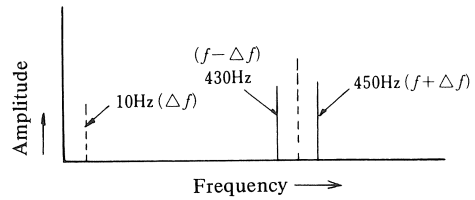
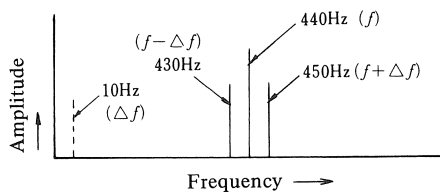

Amplitude modulation

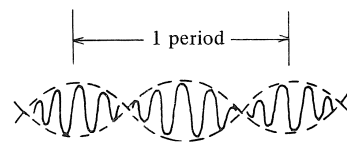

Ring modulation

When the musical signal components are removed from the wave shapes shown at the left, those shown at the right result.

These two frequency components ( $f + \Delta f$  and  $f - \Delta f$ ) give the following effects:

- 1) When the modulation signal frequency is low ( $\Delta f < 10$  Hz), the difference sound ( $2 \Delta f$ ) between the two is not audible to the ear, and only the changes in amplitude (beating at  $2 \Delta f$ ) can be felt, giving a sort of tremolo effect.

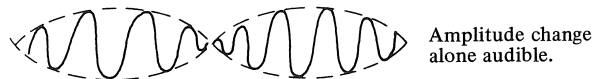

- 2) When the modulation signal frequency is high ( $\Delta f > 10$  Hz), the changes in amplitude become difficult to perceive, but the difference sound is audible, giving a non-harmonious sound effect with the difference sound and two frequency components ( $f + \Delta f$ ,  $f - \Delta f$ ).

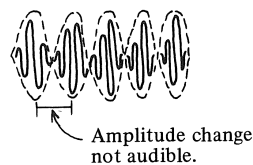

[OUTLINE OF OPERATION]

• Ring Modulator

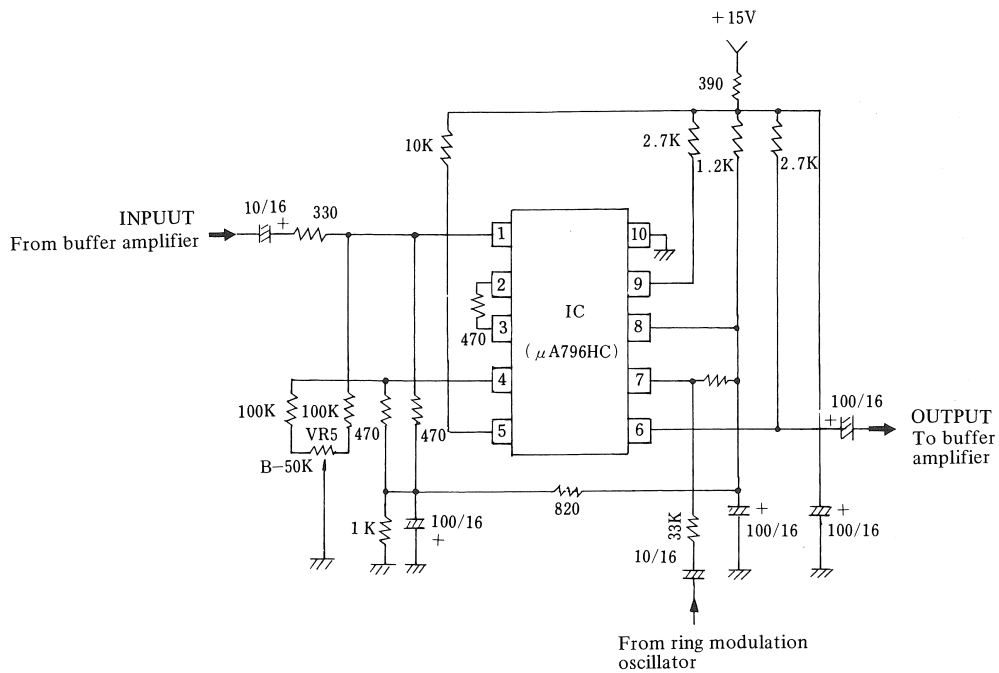

By the low frequency modulation signal from the ring modulation oscillator, ring modulation is conducted. The sound signal from the M circuit board passes through the buffer amplifier and is input into the No. 1 pin of the IC for ring modulation. The signal accepts the ring modulation by the low frequency modulation signal to be added to the No. 7 pin, and is output in the No. 6 pin. Theoretically, when one of the two signals is not input, the output of RMO terminal becomes zero. However, the modulation signal is characterized by leakage output according to IC aberration. The VR5 adjusts and controls the leakage signal to less than 3mVp-p.

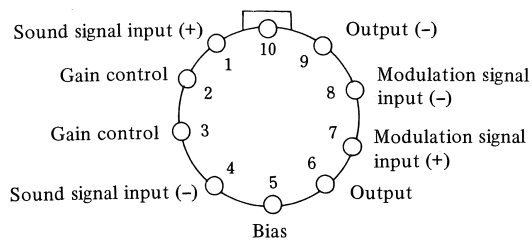

IC  $\mu$ A796HC

NOTE: Terminal layout of IC ( $\mu$ A796HC) in can-type package.

● RING MODULATION SIGNAL OSCILLATOR

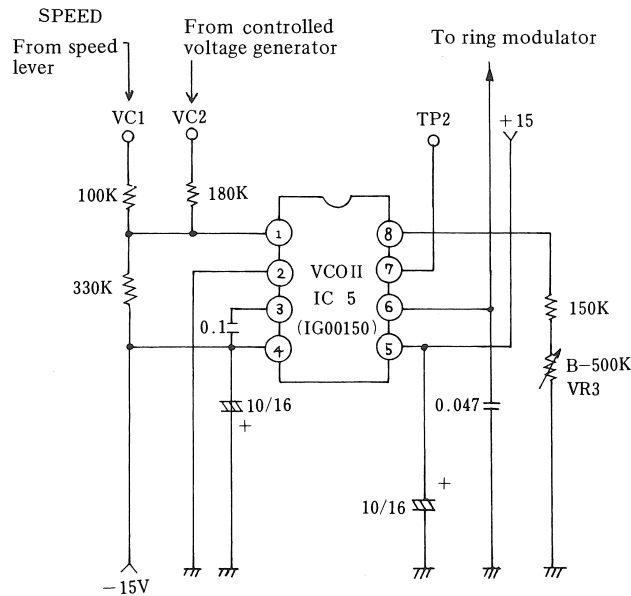

This circuit is a VCO controlled by the voltage from the control voltage generator through SPEED and DEPTH control levers. Its output is used as the modulation signal (variable for 0.2 – 220 Hz). For the principle of operation, see the section on the PWM oscillator.

● CONTROL VOLTAGE GENERATOR

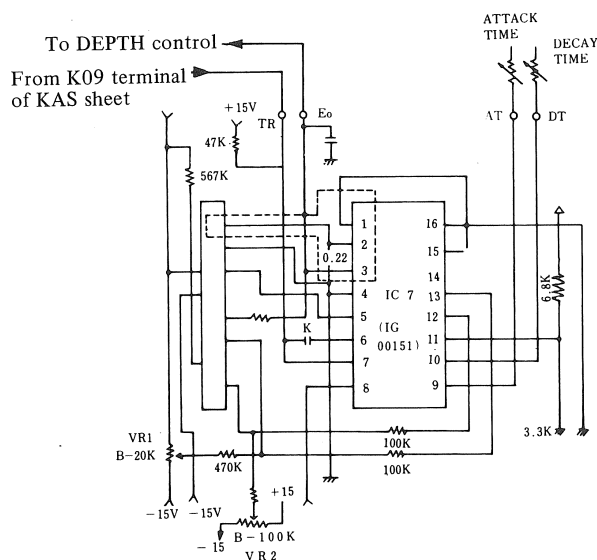

In this circuit, the rising and fast-decaying envelope voltages are controlled on the basis of key-ON signal from the KAS circuit board by use of ATTACK TIME and DECAY TIME controls, and the output is fed into the ring modulation signal oscillator through the DEPTH control. For the principle of operation, refer to the section of envelope generator.



● **SUB-OSCILLATOR**

The low frequency modulation signals (sine and sawtooth waves) of 0.8 to 50 Hz are produced by use of SPEED lever.

[Sub-oscillator and wave shaper converter]

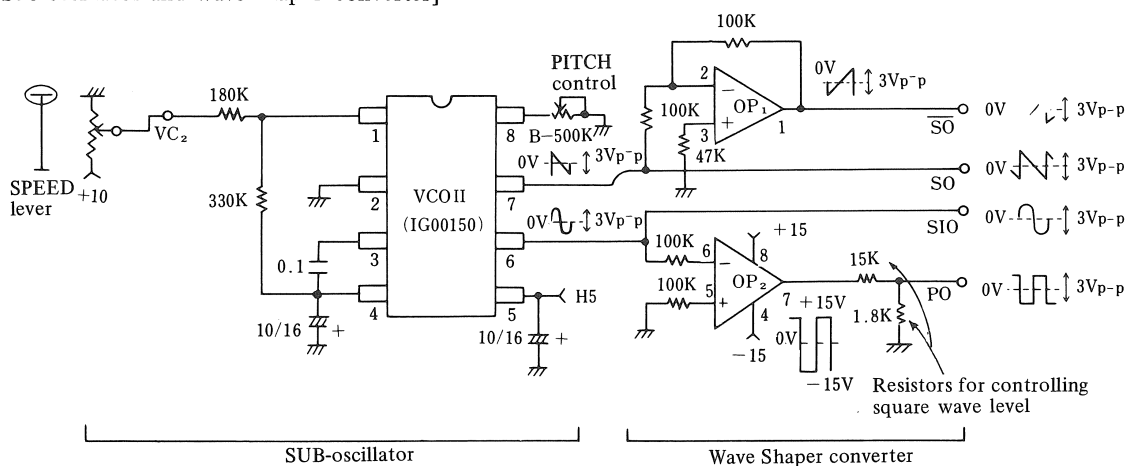

NOTE: OP<sub>1</sub> and OP<sub>2</sub> are paired in IC (NJM4558)

(a) **Sub-oscillator**

The low frequency modulation signals (sine and sawtooth waves) of 0.8 to 50Hz are produced by use of SPEED lever.

The sub-oscillator is a sort of voltage-controlled oscillator (VCO II). The SPEED lever applies 0 to 10V to VC<sub>2</sub> terminal. This voltage controls the frequency of VCO II oscillation. The higher the voltage is, the higher becomes the frequency. (The level of the signal is fixed at 3V<sub>p-p</sub>.)

VC <sub>2</sub> terminal voltage	VCO II oscillation frequency
0 V	0.8 ± 0.16Hz
5 V	6.7 ± 1.3 Hz
10V	50 ± 10 Hz

In this circuit, the VCO II frequency should be adjusted at VR7 (B-500k) in relation to the voltage at the VC<sub>2</sub> terminal, as shown at the left.

The VCO II produces the sawtooth wave in its IC, and shapes it into the sine wave, to be output at PIN 7 and PIN 6, respectively.

(b) **Wave Shaper Converter**

This circuit converts the sine wave created by the VCO II into the square wave, and the sawtooth wave into an inverted sawtooth wave by use of the operational amplifier.

(Sine wave → Square wave)

For converting the sine wave into a square wave, the OP amplifier is used as a zero cross detector or comparator. The OP amplifier does not include a feedback loop and operates with gain A<sub>o</sub>. If the required voltage is 5V and A<sub>o</sub> = 50,000

$$V_o/A_o = 5/50,000 = 100 (\mu V)$$

Accordingly, the balance point of OP amplifier input is set at 0V, and an alternating voltage is applied. Then plus and minus saturations at ±100 μV are obtained around 0V.

In this circuit, the plus input is compared with the minus input. If the gain of the OP amplifier is infinitely great,



the output saturates in the positive side when the plus input is higher than the minus input, and in the negative side when the plus input is lower than the minus input. In practice,  $\pm 15V$  is applied as the DC supply, and the saturation is attained at this level.

**(Sawtooth wave  $\rightarrow$  Inversive sawtooth wave)**

For inverting the sawtooth wave, the OP amplifier is used as an inverting amplifier with gain 1.

**(Noise wave)**

The white noise generated by the noise generator is turned into the pink noise by the low pass filter. The latter is provided as one of the modulation signals. (Refer to the section of Noise Generator.)

**(EXT signal)**

Besides the signals created by the synthesizer, the low frequency signal, human voice, Auto Rhythm signal, other audio signals or any other signals may be used as the modulation signal.

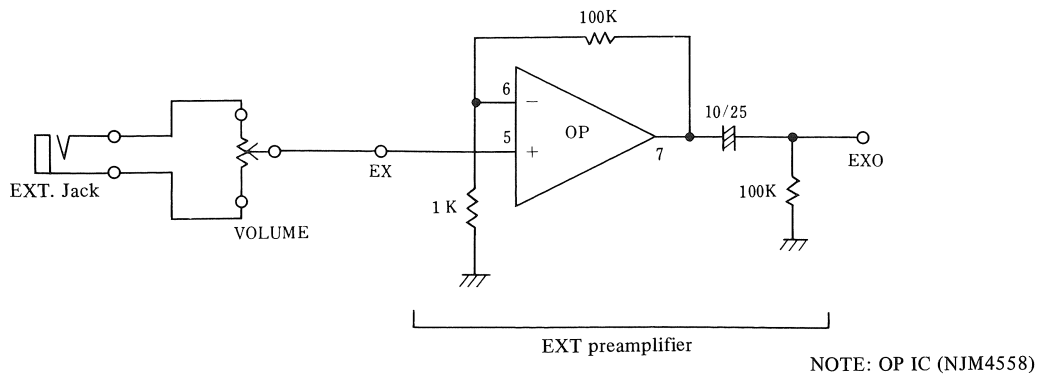

These modulation signals are to be fed into VCO III, VCF and VCA.

● **TOUCH RESPONSE**

The touch response effect is obtained by detecting the DC voltage proportional to the strength with which the key is depressed (or the depth to which the key is depressed) and using it as the control voltage. Applying this voltage VCO, VCF and VCA, the pitch, tone and loudness are controlled in accordance with the degree of key depression. When this voltage is applied to the level control circuit (consisting of VCA) for modulation signal from the sub-oscillator, the depth of modulation can be controlled in accordance with the strength of depressing the key.

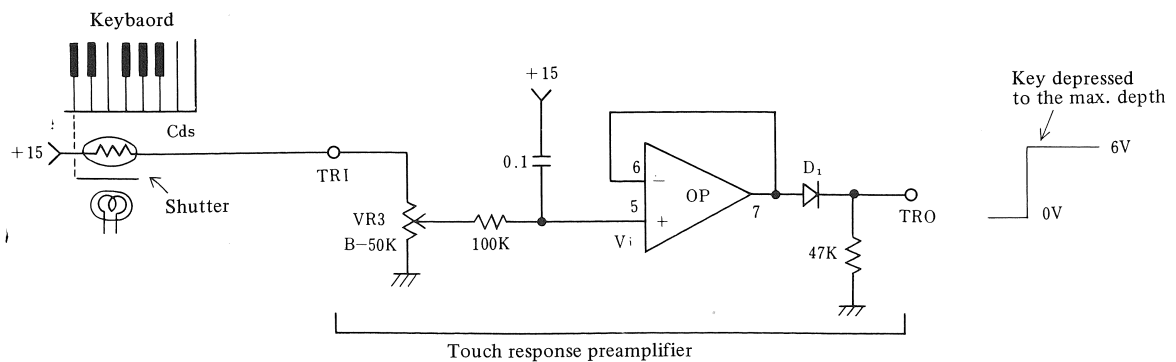

**[Outline of Operation]**

The conductance of CdS conductor is determined by the illumination it receives from the LED which in turn is controlled by the slit position on the shutter plate interlocked with the key. If the key is depressed deeper, the CdS receives more light to increase its conductance, raising the input voltage, and hence, the output voltage of positive input amplifier (OP amplifier). In this way, the touch response effect is obtained. The output voltage (control voltage) of this circuit is adjusted by VR3 so as to be 6.0V when the key is depressed to the maximum depth. D<sub>1</sub> is inserted for the purpose of shifting the voltage so as to make the output voltage zero when the key is not depressed by canceling the mechanical failure of the shutter plate and the off-set voltage of OP amplifier.

Reference:

$$V_i = \frac{B50k}{R_{cds} + B50k} \times 15(V) \quad B50K : \text{voltage level gain}$$

● **LEVEL CONTROL AMPLIFIER**

This circuit allows to control the degree of modulation by the sub-oscillator signal with the key touch.

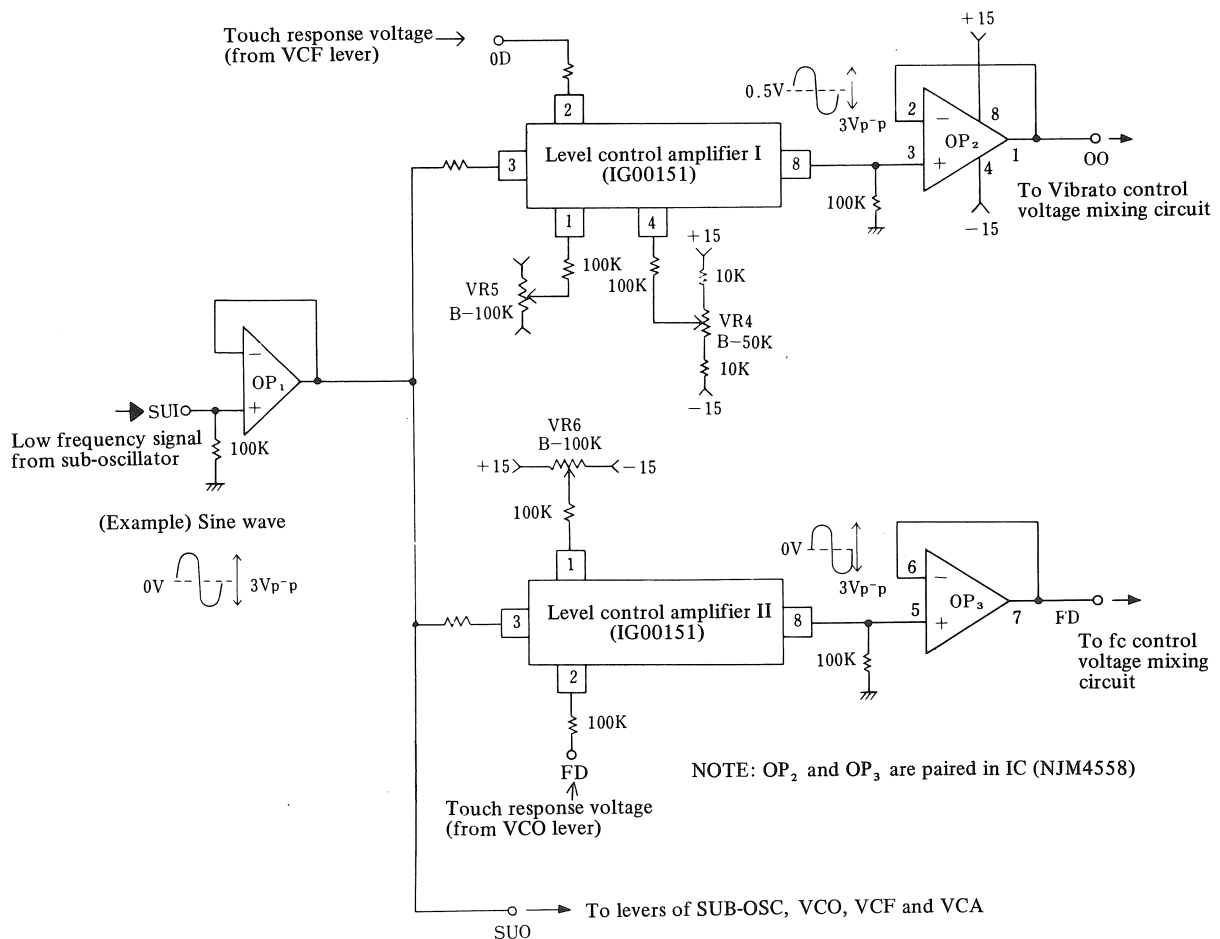

Three OP amplifiers OP<sub>1</sub>, OP<sub>2</sub> and OP<sub>3</sub> are used as buffer amplifiers. The level control amplifiers I and II are voltage controlled amplifiers (VCA), with their gains controlled by the voltage fed into PIN 2: the higher the voltage, the greater will be the gain.

---

**[Outline of Operation]**

The low frequency signal selected by function switch of the sub-oscillator is fed into SUI terminal and led to PIN 3 of level control amplifiers I and II through the bufer amplifier OP<sub>1</sub>. Since the gain of level control amplifier is controlled by the touch response voltage at PIN 2 terminal, the output voltage become higher or lower as the key is depressed stronger or lighter, respectively.

The circuit is adjusted by either of VR5 or VR6 so that the input level is equal to the output level, when 6V is applied to PIN 2 of each level control amplifier. In the level control amplifier I, VR4 is adjusted so that 0.5V – centered output wave shape is obtained when 0V-centered input voltage is fed.

(If the center musical interval is raised a little, the vibrato effect to move the interval up and down periodically is perceived more naturally.)

# CONTROL VOLTAGE MIXING CIRCUIT

## 1. VCO VIBRATO CONTROL VOLTAGE MIXING CIRCUIT

This circuit is to mix various control voltages for V terminal of VCO. The vibrato effect is controlled by the mixed voltage.

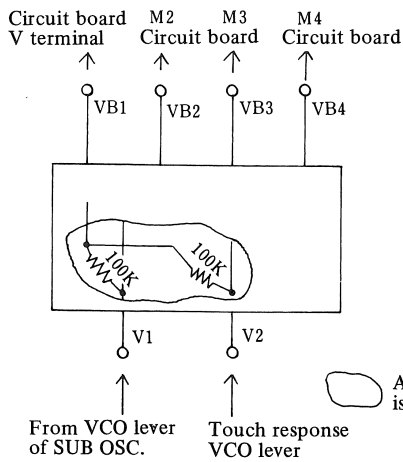

(Reference) When all the output terminals are loaded with 1 k $\Omega$  and all the input terminals are applied with 10 V, the voltage at output terminals (VB1 – VB4) is 200 mV.

NOTE: Input through level control circuit.

## 2. VCF CUT-OFF FREQUENCY ( $f_c$ ) CONTROL VOLTAGE MIXING CIRCUIT

In this circuit various control voltages to be fed into  $f_1$  terminal of VCF-HPF and  $f_2$  terminal of VCF-LPF are mixed. The cut-off frequency is controlled by the mixed voltage.

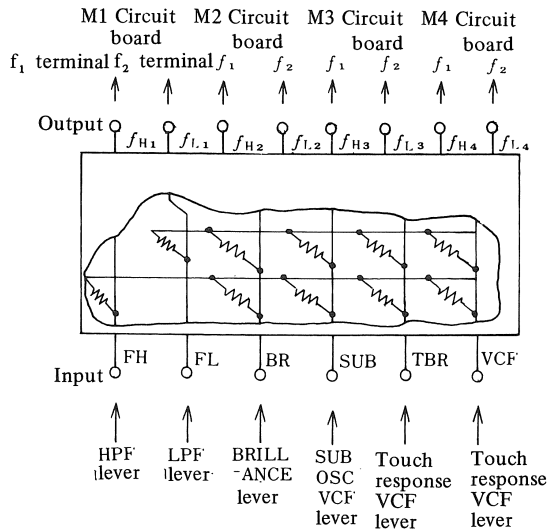

(Reference) When all the output terminals are loaded with 1 k $\Omega$  and all the input terminals are applied with +10V, the output voltage at  $f_{H1}$ ,  $f_{H2}$ ,  $f_{H3}$ ,  $f_{H4}$  is 0.45V, and that at  $f_{L1}$ ,  $f_{L2}$ ,  $f_{L3}$ ,  $f_{L4}$  is 0.64V.

NOTE: Input through level control circuit.

## 3. VCF RESONANCE (Q) CONTROL VOLTAGE MIXING CIRCUIT

In this circuit various control voltages to be applied to  $Q_1$  terminal of VCF-HPF and  $Q_2$  terminal of VCF-LPF are mixed. The resonance (Q) is controlled by the mixed voltage.

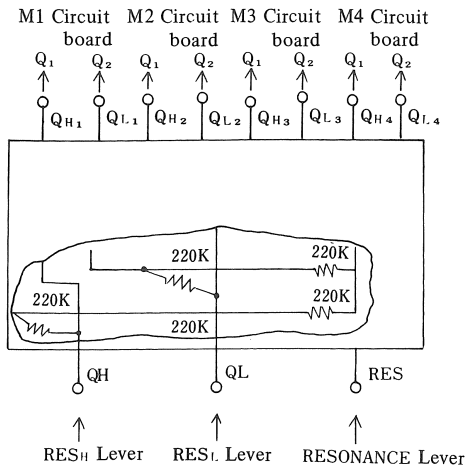

(Reference) When all the output terminals are loaded with 1 kΩ and all the input terminals are applied with 10V, the output voltage at terminals. Q<sub>H1</sub> ~ Q<sub>H4</sub> is 90 mV.

#### 4. VCA CONTROL VOLTAGE MIXING CIRCUIT

In this circuit, various control voltages to be applied to LC terminal of VCA are mixed. The signal level is controlled by the mixed voltage.

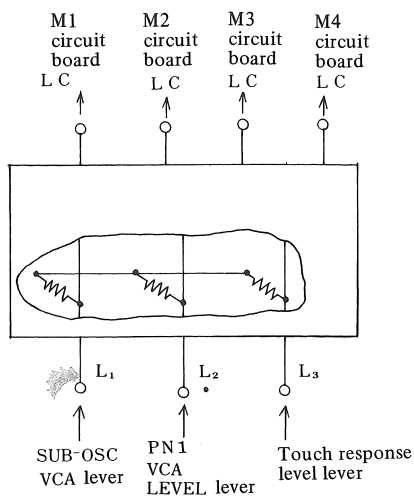

(Reference) When all the output terminals are loaded with 1kΩ and all the input terminals (L<sub>1</sub> ~ L<sub>3</sub>) are applied with +10V, the output voltage at terminals L<sub>1</sub> ~ L<sub>4</sub> is 0.18V.

# OTHER CIRCUITS

## 1. SUSTAIN CONTROL CIRCUIT

This circuit controls the priority relationship between the SUSTAIN lever on Panel 3 and RELEASE control lever for VCF and VCA on Panel 1.

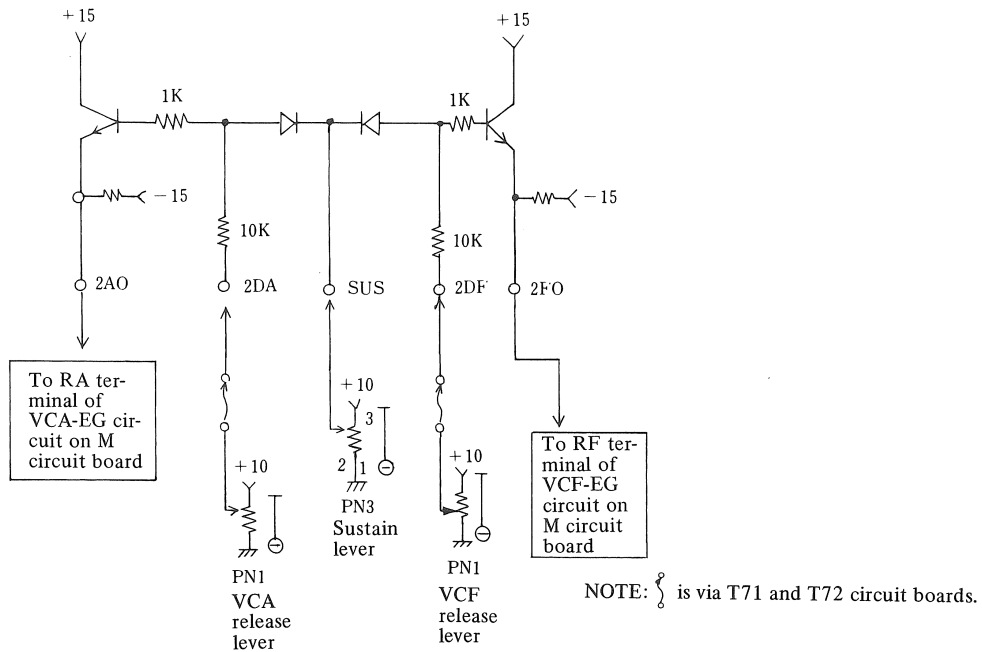

The input voltage at SUS terminal is compared with that at 2DF or 2AO terminal, and the lower voltage is output at 2FO or 2DA terminal. This controls VCF-EG or VCA-EG circuit to set the time from the key release to the die-out and the course of cut-off frequency (fc) change of VCF during the release time.

## 2. TUNING VOLTAGE CIRCUIT

The D-A converter of the key assigner circuit includes a voltage network consisting of resistors for the purpose of providing the analog voltage corresponding to the octave in which the note for the depressed key is included. To this network, +15V is applied as the reference voltage. If a voltage control circuit as illustrated is inserted to between +15V and the network, the analog voltage for each octave can be displaced in parallel, allowing the tuning control.

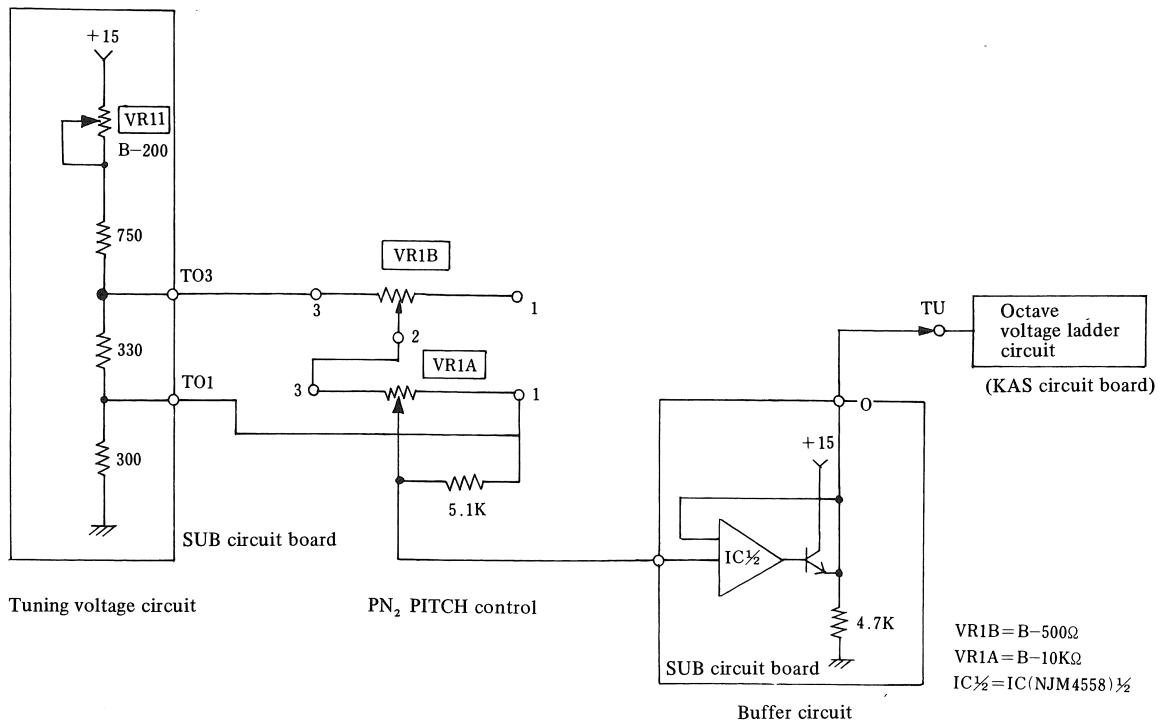

### [Operation]

The reference voltage +15V is divided by the tuning voltage circuit and the variable resistor of pitch control, and the resultant voltage is stabilized by the buffer circuit and applied to the octave voltage ladder network (KAS circuit-board). This is the reference key voltage.

In this circuit, the voltage at the output terminal (O) can be varied from 3 to 6V by use of PITCH control on Panel 1. VR11 (B-200Ω) is adjusted so that 4V is given at 0 terminal when the PITCH control is positioned centrally. The PITCH control is a dual variable resistor, consisting of coarse control (VR1A) and fine control (VR1B). (See the illustrations below.)

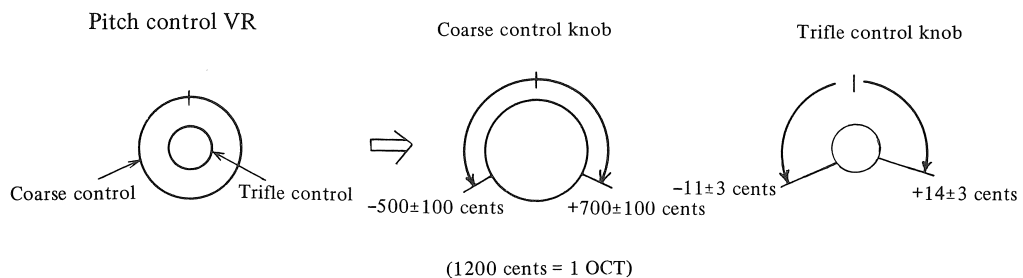

### 3. PRESET TONE SETTING VOLTAGE DIVIDER CIRCUIT (RESISTOR MATRIX)

This circuit sets the control voltage for creating the tone color indicated on the tone selector. The circuit consists of resistors to divide +10V supplied from the tone selector so as to provide the control voltage for determining the tone color at the output terminals (a to v).

The diodes are to prevent the mutual interference of control voltage.

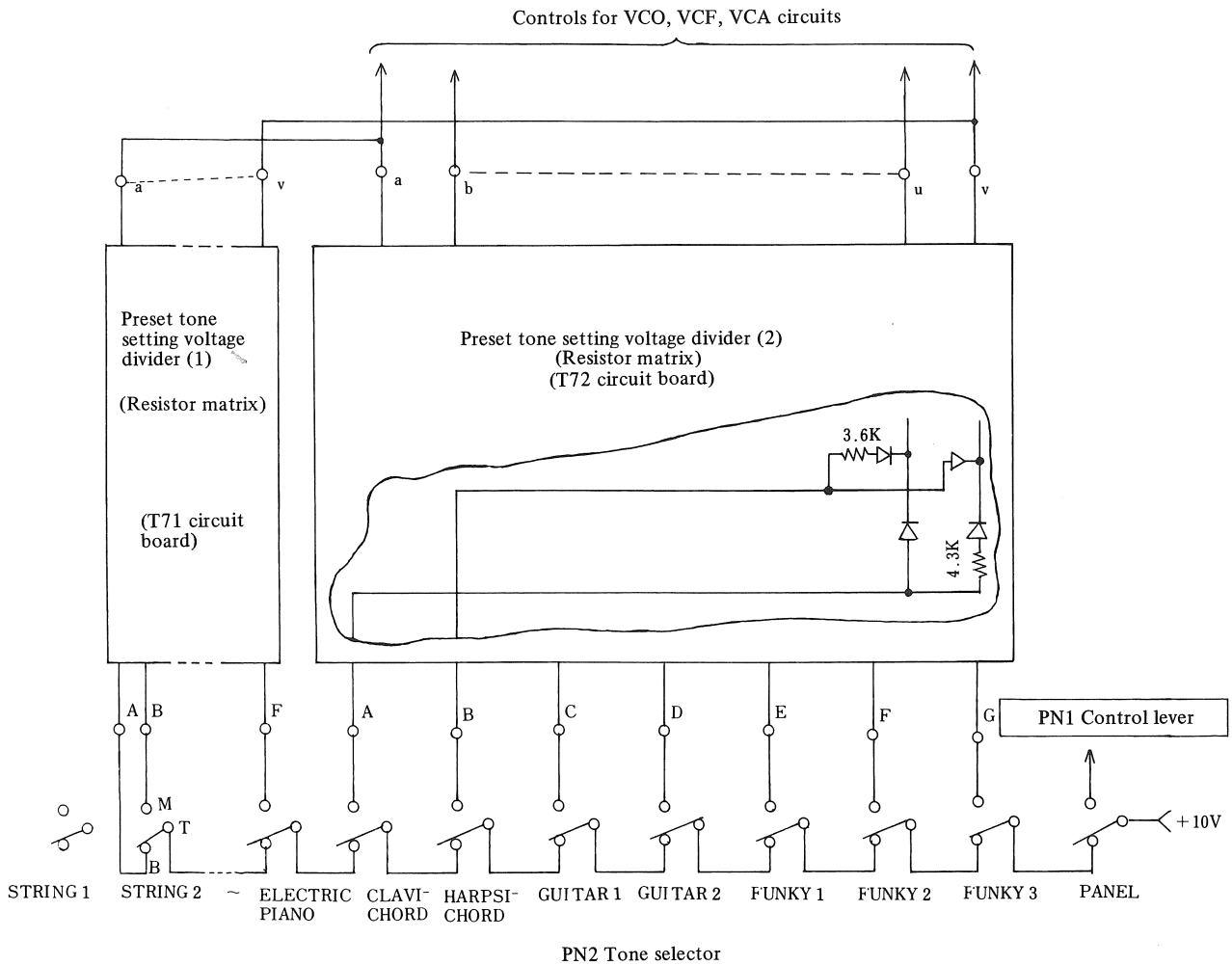

T71 circuit board and T72 circuit board constitute the resistor voltage dividers corresponding to respective tone selectors. performing similar functions. Accordingly, all the output terminals (a ~ v) are connected in common to supply the voltage for controlling VCO, VCF and VCA circuits. The tone selector switch has priority for the right-hand-side. When all the tone selector switches are off, STRING 1 is automatically set.



	Control by output voltage	VCO			Gate			HPF		LPF		VCF-EG				VCA	VCA	VCA-EG			VCA		
		Pulse width modulation period	Pulse width modulation depth	Pulse width	Gate sound source square wave	Gate of sound source sawtooth wave	Sound source noise level	Cut-off frequency (fc)	Resonance (Q)	Cut-off frequency (fc)	Resonance (Q)	Initial level	Attack level	Attack time	Decay time	Release time	VCF sound signal level	Sine wave level	Attack time	Decay time	Sustain level	Release time	Sine wave signal level
Tone selector	Output Input	a	b	c	d	e	f	g	h	i	j	k	l	m	n	o	p	q	r	s	t	u	v
STRING 1	A	0	0	0	0	10	0	5.00	6.17	5.70	10	3.85	6.80	2.50	4.55	6.80	10	0.43	1.52	1.09	8.47	8.85	10
STRING 2	B	0	0	0	0	10	0	2.33	10	5.95	10	0	5.49	5.00	0.63	6.80	10	0	4.35	10	8.47	6.99	8.47
BRASS 1	C	0	0	0	0	10	0	0	10	5.71	5.71	1.89	3.57	1.39	1.64	10	10	0.43	5.24	2.04	6.17	10	10
BRASS 2	D	0	0	0	0	10	0	2.17	3.85	3.84	7.87	2.70	8.70	4.00	3.85	7.19	10	0	5.49	4.35	4.76	6.62	8333
FLUTE	E	0	0	0	0	10	0	1.18	3.57	5.24	2.33	5.24	0.63	3.57	1.68	7.35	10	0	3.13	0	5.24	7.19	10
ELECTRIC PIANO	F	0	0.63	3.35	10	0	0	1.28	6.41	1.52	3.33	0	4.76	7.52	2.57	10	10	4.35	10	2.17	0.63	6.41	10
CLAVICHORD	A	0	0	7.19	10	10	0	5.24	5.95	5.71	4.55	0	4.55	10	2.23	7.52	10	0	10	3.33	1.28	10	6.99
HARPSICHORD	B	0	0	5.95	10	0	0	6.41	10	7.87	8.47	0	0	0	0	0	10	0	10	2.17	0	7.35	10
GUITAR 1	C	0	0	4.55	10	0	0	3.85	5.49	5.95	2.50	0.43	2.94	10	5.00	10	10	0	7.52	3.85	1.64	6.41	8.33
GUITAR 2	D	0	0	0	0	10	0	2.50	0	2.70	0	0	7.52	10	2.19	7.19	10	5.24	10	0.99	0.43	8.06	6.41
FUNKY 1	E	2.33	0.91	5.41	10	10	0	5.00	6.17	5.95	0	10	6.80	10	6.68	4.76	10	3.33	10	10	8.47	8.85	5.00
FUNKY 2	F	0	0	6.62	0	10	0	5.71	0	7.35	0	9.09	9.59	6.41	5.49	9.30	10	5.24	10	0	4.76	10	6.80
FUNKY 3	G	0	0	0	10	0	0	4.00	2.50	4.76	3.13	0	9.47	6117	4.00	7.19	10	0	7.19	10	8.47	7.35	5.95

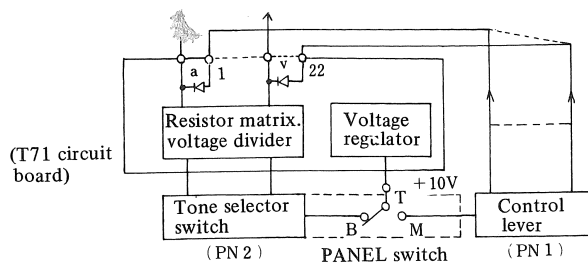

The DC supply voltage selected by the control lever on Panel 1 is input to terminals 1 to 22 of T71 circuit board, and after being divided by resistors, output to terminals a to v through diodes.

The input voltage +10V is produced by the voltage regulator in the T71 circuit board and led to the moving contact (T) of Pre-set tone Selector switches on the panel. When the PANEL lever is turned OFF or ON, the tone selector or the control lever, respectively, becomes effective. That is, both the tone selector and the control lever of Panel 1 control the same circuit, the former selecting the preset voltage, while the latter the controllable voltage.

# TUNING METHOD

**Before starting the tuning operation, warm up the instrument for 10 minutes or longer.**

1. Set PITCH control at center. Adjust VR11 (B-200 $\Omega$ ) on the SUB circuit board so that the TU terminal on the KAS circuit board gives +4V  $\pm$ 0.1% with respect to the E terminal. Keep all of the panel levers OFF.
2. Set the tone selector to FLUTE and the transposition lever to OCT-UP (VIII terminal of M circuit at +15V). Adjust VR1 (B-10k $\Omega$ ) on the M circuit board so that the voltage at CP6 terminal is within  $\pm$ 120  $\mu$ V when the EK terminal is shorted to the E terminal on the M circuit board.
3. Adjust four circuit boards one by one as indicated below, checking the output at T1 terminal (check point 9 PIN of IC9). Adjust VR3 so that the output gives C7 (4186 Hz)  $\pm$ 1 cent when C6 key is depressed, and C3 (261.6 Hz)  $\pm$ 1 cent when C2 key is depressed. Repeat these steps a few times. (To check the correspondence of depressed key to M circuit board, touch VR2 on one of M circuit board while the sound is produced. If the musical interval is modulated by hum, the M circuit board under check is producing the sound.)
4. Similarly, setting the transposition lever to NORMAL (VI terminal 15V), adjust VR4 (B-1k $\Omega$ ) so that C6 (2093 Hz)  $\pm$ 1 cent is obtained when C6 key is depressed.
5. Setting the transposition lever to 1 OCT DOWN (II terminal 15V), adjust VR5 (B-2k $\Omega$ ) so that C5 (1046 Hz)  $\pm$ 1 cent is obtained when C6 key is depressed. Then, setting the transposition lever to 2 OCT DOWN (I terminal 15V), adjust VR6 (B-5k $\Omega$ ) so that C4 (523.2 Hz)  $\pm$ 1 cent is obtained when C6 key is depressed.

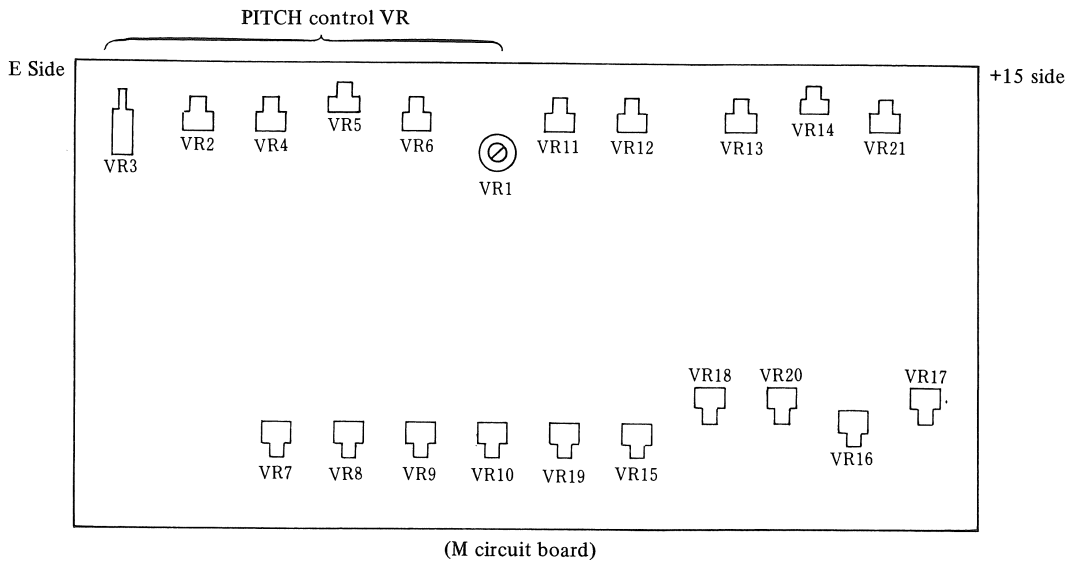





SINCE 1887  **YAMAHA**  
NIPPON GAKKI CO., LTD. HAMAMATSU, JAPAN